

Plate Cylinder

MU Series

ø25, ø32, ø40, ø50, ø63

RoHS

It is possible to mount small auto switches in 4 directions. No stick-out
Easy mounting

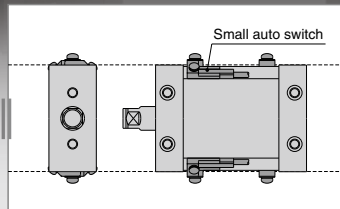
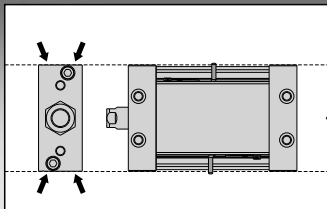
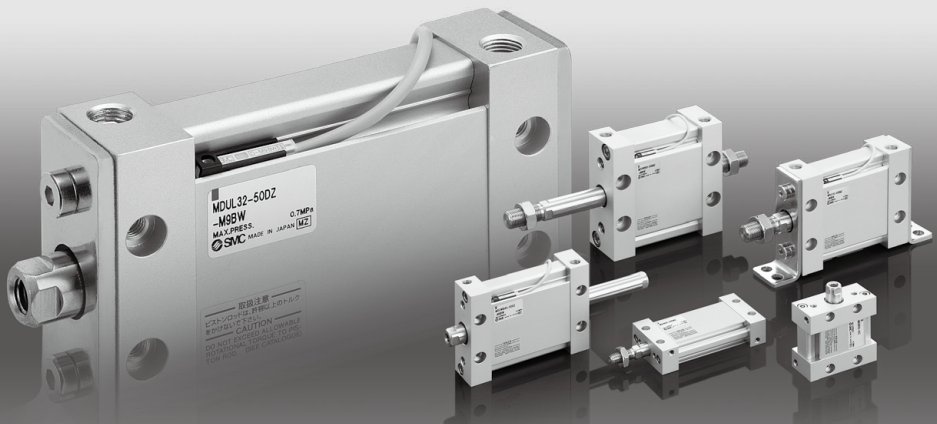

● Reduction of labor for work

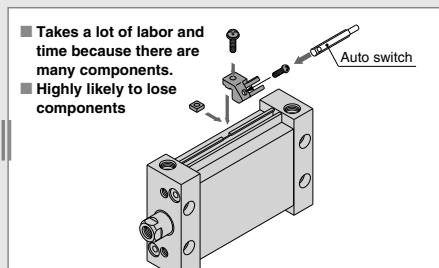
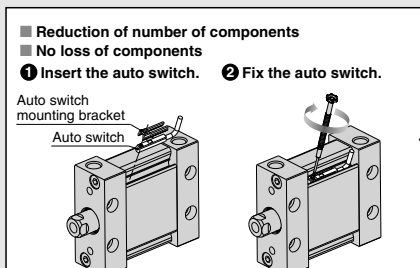

● Available with a stroke up to 300 mm

CUJ

CU

CQS

JCQ

CQ2

RQ

CQM

CQU

MU

D-□

-X□

Technical Data

MU Series



- **Width: Max. 62% reduction**
(in comparison with SMC CA2 cylinder)

- **Can be mounted without brackets and in flexible ways.**



Size	A		
	MU	CA2	Reduction rate
25	24	60	60%
32	28	70	60%
40	32	85	62%
50	39	102	62%
63	50	116	57%

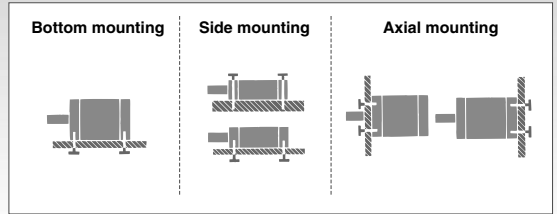

- **Can be mounted with short pitch.**
* Without auto switch

- **Various brackets are available to accommodate a wide range of applications.**

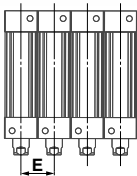

Size	E (mm)
25	24
32	28
40	32
50	39
63	50

(Note) When the auto switch is mounted, the minimum mounting pitch is restricted as shown in the catalog.

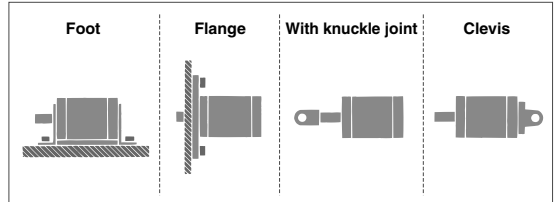

2-Color indicator Solid State Auto Switch

Appropriate setting of the mounting position can be performed without mistakes.

- **For general environments**

- **Water resistant type**
For environments exposed to water and coolant

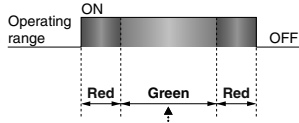
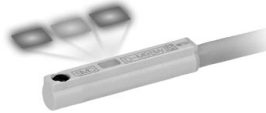

A green light lights up at the proper operating range.

Proper operating range

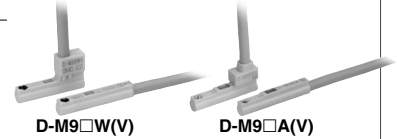

Even if 2-color indicator solid state auto switches are fixed at a proper operating range (the green light lights up), the operation may become unstable depending on the installation environment or magnetic field disturbance.

(Magnetic body, external magnetic field, proximal installation of cylinders with built-in magnet and actuators, temperature change, other factors for magnetic force fluctuation during operation, etc.)

Series Variations

Action	Type	Size	Standard stroke (mm)																Rod end configuration		
			5	10	15	20	25	30	35	40	45	50	75	100	125	150	175	200		250	300
Double acting	Single rod	25	●	●	●	●	●	●	●	●	●	●	●	●	●	●	●	●	●	●	Male thread, Female thread
	Double rod	32	●	●	●	●	●	●	●	●	●	●	●	●	●	●	●	●	●	●	
		40	●	●	●	●	●	●	●	●	●	●	●	●	●	●	●	●	●	●	
		50	●	●	●	●	●	●	●	●	●	●	●	●	●	●	●	●	●	●	
Single acting	Spring return, Spring extend	25	●	●	●	●	●	●	●	●	●	●	●	●	●	●	●	●	●	●	
		32	●	●	●	●	●	●	●	●	●	●	●	●	●	●	●	●	●	●	
		40	●	●	●	●	●	●	●	●	●	●	●	●	●	●	●	●	●	●	
		50	●	●	●	●	●	●	●	●	●	●	●	●	●	●	●	●	●	●	
	63	●	●	●	●	●	●	●	●	●	●	●	●	●	●	●	●	●	●		

Rod End Allowable Load

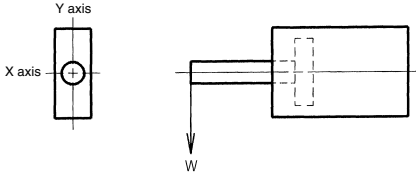

* In case of a plate cylinder, although there is the case that a load is applied in both X and Y axis as illustrated, but the allowable lateral load is the same.

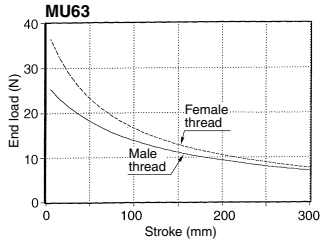
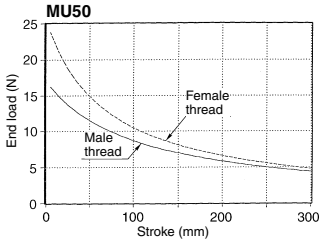
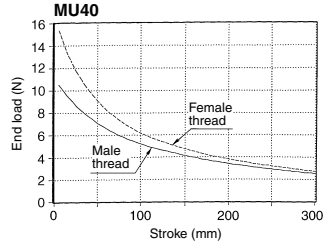
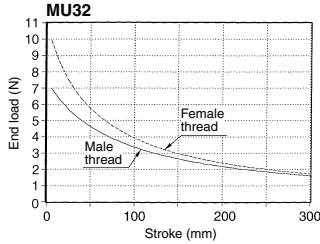
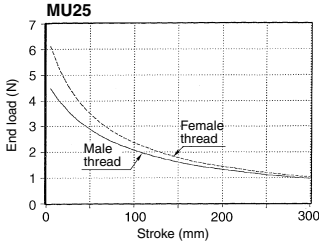

Plate Cylinder Operating Precautions

1. Operating speed

Make sure to connect a speed controller to the cylinder and adjust its speed to 500 mm/s or less.

When a load is applied to the rod end, adjust the speed so that the maximum speed should be no more than that shown in the chart for the corresponding load mass.

<Chart> MU series

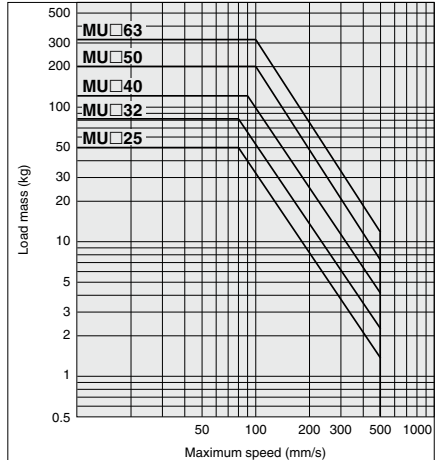

CUJ

CU

CQS

JCQ

CQ2

RQ

CQM

CQU

MU

D-□

-X□

Technical Data

Plate Cylinder: Double Acting, Single Rod

MU Series

ø25, ø32, ø40, ø50, ø63

RoHS

How to Order

MU B 25 - 30 D M Z

With auto switch MDU B 25 - 30 D M Z - M9BW S

With auto switch
(Built-in magnet)

Mounting

B	Basic
L	Foot
F	Rod flange
G	Head flange
C	Single clevis
D	Double clevis

* Brackets are shipped together, (but not assembled).

Size

25	Equiv. ø25 piston area
32	Equiv. ø32 piston area
40	Equiv. ø40 piston area
50	Equiv. ø50 piston area
63	Equiv. ø63 piston area

Port thread type

Nil	M thread	ø25
	Rc	
TN	NPT	ø32, ø40
TF	G	ø50, ø63

Number of auto switches

Nil	2 pcs.
S	1 pc.
n	"n" pcs.

Auto switch

Nil	Without auto switch
------------	---------------------

* Refer to the below table for applicable auto switch models.

Rod end configuration

Nil	Rod end female thread
M	Rod end male thread

Action

D	Double acting
----------	---------------

Cylinder stroke (mm)
Refer to "Standard Stroke" on page 1037.

Built-in Magnet Cylinder Model
If a built-in magnet cylinder without an auto switch is required, there is no need to enter the symbol for the auto switch. (Example) MDUL32-30DZ

Applicable Auto Switches

Refer to pages 1575 to 1701 for further information on auto switches.

Type	Special function	Electrical entry	Indicator light	Wiring (Output)	Load voltage		Auto switch model		Lead wire length (m)			Pre-wired connector	Applicable load					
					DC	AC	Perpendicular	In-line	0.5 (Nil)	1 (M)	3 (L)			5 (Z)				
Solid state auto switch	—	Grommet	Yes	3-wire (NPN)	5 V, 12 V	—	M9NV	M9N	●	●	○	○	IC circuit					
				3-wire (PNP)			M9PV	M9P	●	●	○	○						
	Diagnostic indication (2-color indicator)			2-wire	12 V		M9BV	M9B	●	●	○	○	—					
				3-wire (NPN)			M9NVW	M9NW	●	●	○	○	IC circuit					
	Water resistant (2-color indicator)			3-wire (PNP)	5 V, 12 V		M9PWV	M9PW	●	●	○	○		IC circuit				
				2-wire			M9BWV	M9BW	●	●	○	○						
	Magnetic field resistant (2-color indicator)			3-wire (NPN)	5 V, 12 V		M9NAV *1	M9NA *1	○	○	●	○	IC circuit					
				3-wire (PNP)			M9PAV *1	M9PA *1	○	○	●	○						
								2-wire	12 V		M9BAV *1	M9BA *1	○	○	○	○		
								2-wire (Non-polar)			—	P3DWA (Note 2)	●	—	●	○		
Reed auto switch	—	Grommet	Yes	3-wire (NPN equivalent)	—	5 V	A96V	A96	●	—	—	—	IC circuit	Relay, PLC				
				None			2-wire	24 V	12 V	100 V	A93V *2	A93	●		●	●	—	—
										100 V or less	A90V	A90	●		—	●	—	—

*1 Water resistant type auto switches can be mounted on the above models, but in such case SMC cannot guarantee water resistance.

Consult with SMC regarding water resistant types with the above model numbers.

*2 1 m type lead wire is only applicable to D-A93.

* Lead wire length symbols: 0.5 m Nil (Example) M9NW
1 m M (Example) M9NWM
3 m L (Example) M9NLW
5 m Z (Example) M9NWZ

* Solid state auto switches marked with "○" are produced upon receipt of order.

* For details about auto switches with pre-wired connector, refer to pages 1648 and 1649.

* Auto switches are shipped together, (but not assembled).

Note 1) The D-M9□V/M9□WV/M9□AV/A9□V auto switches cannot be mounted on the ported surface with some cylinder strokes and sizes of fittings. This should be checked beforehand.

Note 2) The magnetic field resistant auto switch (D-P3DWA□) is available the current MU series. Refer to page 1058 for the how-to-order.

Specifications



Symbol

Rubber bumper (Oval piston)

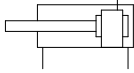

Bore size (mm)	25	32	40	50	63
Action	Double acting, Single rod				
Fluid	Air				
Proof pressure	1.05 MPa				
Maximum operating pressure	0.7 MPa				
Minimum operating pressure	0.05 MPa				
Ambient and fluid temperature	-10 to 60°C				
Lubrication	Not required (Non-lube)				
Piston speed	50 to 500 mm/s				
Stroke length tolerance	+1.4 0				
Cushion	Rubber bumper				
Mounting	Foot, Rod flange, Head flange, Single clevis, Double clevis				
Rod end configuration	Rod end male thread, Rod end female thread				
Allowable rotational torque	0.25 N·m	0.55 N·m	1.25 N·m	2.0 N·m	
Rod non-rotating accuracy	±1°	±0.8°			±0.5°

Standard Stroke

Size	Standard stroke (mm)	Maximum manufacturable stroke (mm)
25, 32, 40	5, 10, 15, 20, 25, 30, 35, 40, 45, 50	300
50, 63	75, 100, 125, 150, 175, 200, 250, 300	

* Other intermediate strokes can be manufactured upon receipt of order. Please contact SMC.

** Strokes longer than 300 mm are not available.

Mounting Bracket/Part No.

Mounting bracket	Size				
	25	32	40	50	63
Foot <small>Note 1)</small>	MU-L02	MU-L03	MU-L04	MU-L05	MU-L06
Flange	MU-F02	MU-F03	MU-F04	MU-F05	MU-F06
Single clevis	MU-C02	MU-C03	MU-C04	MU-C05	MU-C06
Double clevis <small>Note 3)</small>	MU-D02	MU-D03	MU-D04	MU-D05	MU-D06

Note 1) When ordering foot bracket, order 2 pieces per cylinder.

Note 2) Accessories for each mounting bracket are as follows.

Foot/Flange/Single clevis: Body mounting bolt

Double clevis: Clevis pin, Type C retaining ring for axis, Body mounting bolt

Note 3) Clevis pin and retaining ring are shipped together with double clevis.

Note 4) The tightening torque for body mounting bolts is shown in the below table.

Note 5) The application of a locking agent (Example: Loctite 242) to body mounting bolts is recommended.

Recommended Tightening Torque for Mounting Bracket on Body

Bore size	Thread size	Tightening torque (N·m)
MU25	M5 x 0.8	4.9 to 5.9
MU32	M6 x 1	8.28 to 10.12
MU40	M8 x 1.25	19.8 to 24.2
MU50	M10 x 1.5	39.6 to 48.4
MU63	M12 x 1.75	68.4 to 83.6

Accessory (Option)

For details about the single knuckle joint, double knuckle joint, clevis pin, and knuckle pin, refer to pages 1054 and 1055.

CUJ

CU

CQS

JCQ

CQ2

RQ

CQM

CQU

MU

D-□

-X□

Technical Data

Theoretical Output

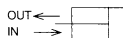

Size	Rod size (mm)	Operating direction	Piston area (mm ²)	Operating pressure (MPa)					
				0.2	0.3	0.4	0.5	0.6	0.7
25	12	OUT	491	98	147	196	246	295	344
		IN	378	76	113	151	189	227	265
32	14	OUT	804	161	241	322	402	482	563
		IN	650	130	195	260	325	390	455
40	16	OUT	1257	251	377	503	629	754	880
		IN	1056	211	317	422	528	634	739
50	20	OUT	1963	393	589	785	982	1178	1374
		IN	1649	330	495	660	824	989	1154
63	20	OUT	3117	623	935	1247	1559	1870	2182
		IN	2803	561	841	1121	1402	1682	1962

(N)
 Note) Theoretical output (N) = Pressure (MPa) x Piston area (mm²)

Weight

Size		25	32	40	50	63
Basic weight	Basic	0.17	0.27	0.39	0.75	1.16
	Foot	0.24	0.41	0.60	1.09	1.79
	Flange/Rod end, Head end	0.27	0.41	0.62	1.21	1.99
	Single clevis	0.23	0.39	0.61	1.15	1.84
	Double clevis (With pin)	0.24	0.43	0.65	1.22	1.92
Additional weight per each 50 mm of stroke		0.09	0.14	0.19	0.28	0.38
Mounting bracket weight	Single clevis (Double clevis pivot bracket)	0.06	0.12	0.22	0.40	0.68
	Double clevis (With pin) (Single clevis pivot bracket)	0.07	0.16	0.26	0.47	0.76
	Single knuckle joint	0.03	0.04	0.07	0.16	0.16
	Double knuckle joint (With pin)	0.05	0.09	0.14	0.29	0.29

Additional Weight

Bore size (mm)		25	32	40	50	63
Rod end male thread	Male thread	12	23	27	53	53
	Nut	8	10	17	32	32

(g)
 Note) Weight of single clevis and double clevis includes 2 bolts for mounting bracket.

Calculation:

(Example) **MUL32-100DZ**

- Basic weight 0.41 (Foot, Equivalent to ø32)
- Additional weight 0.14/50 stroke
- Stroke 100 stroke

$$0.41 + 100/50 \times 0.14 = 0.69 \text{ kg}$$

Construction

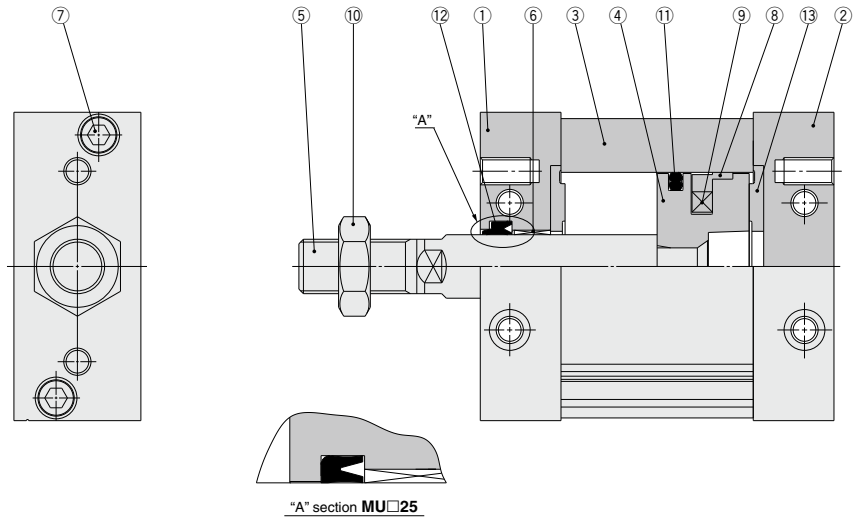

Component Parts

No.	Description	Material	Note
1	Rod cover	Aluminum alloy	Anodized
2	Head cover	Aluminum alloy	Anodized
3	Cylinder tube	Aluminum alloy	Hard anodized
4	Piston	Aluminum die-casted	Chromated
5	Piston rod	Carbon steel	Hard chrome plated
6	Bushing	Bearing alloy	
7	Hexagon socket head cap screw	Stainless steel	
8	Wear ring	Resin	
9	Magnet	—	Only built-in magnet type
10	Rod end nut	Rolled steel	Only attached to rod end male thread
11	Piston seal	NBR	
12	Rod seal	NBR	
13	Bumper	Urethane	

Replacement Parts/Seal Kit

Bore size (mm)	Kit no.	Contents
25	MUB25-PS	Set of nos. above ①, ②, ③
32	MUB32-PS	
40	MUB40-PS	
50	MUB50-PS	
63	MUB63-PS	

- * Seal kit includes ① to ③. Order the seal kit, based on each bore size.
 - * Since the seal kit does not include a grease pack, order it separately.
- Grease pack part no.: GR-S-010 (10 g)**

CUJ

CU

CQS

JCQ

CQ2

RQ

CQM

CQU

MU

D-□

-X□

Technical Data

MU Series

Basic: MUB

Rod end male thread

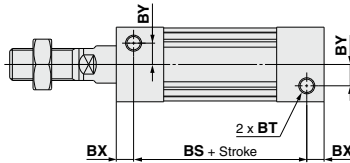
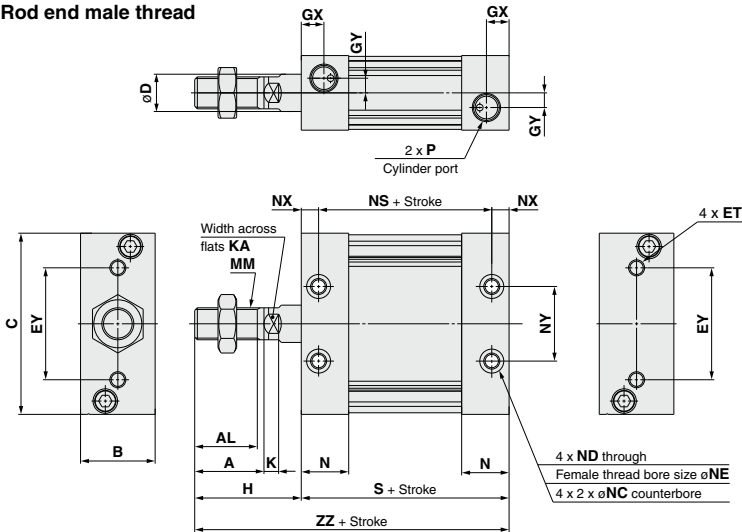

Rod end female thread

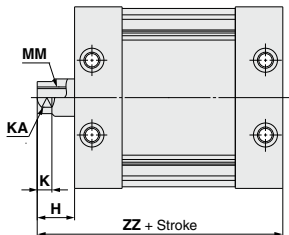

* Dimensions except mentioned on the right are the same as male thread type.
However, K and KA dimensions are the same as male thread type.

Rod end nut

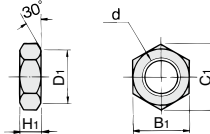

Part no.	Size	d	H ₁	B ₁	C ₁	D ₁
NT-03	25	M10 x 1.25	6	17	19.6	16.5
NT-MU03	32	M12 x 1.25	7	19	21.9	18
NT-04	40	M14 x 1.5	8	22	25.4	21
NT-05	50, 63	M18 x 1.5	11	27	31.2	26

* A nut is attached to the rod end nut material: Carbon steel
End male thread as standard. Surface treatment: Chromated

Model	Stroke range (mm)	A	AL	B	BS	BT	BX	BY	C	D	ET	EY	GX	GY	H	K	KA
MUB25	5 to 300	22	19.5	24	37	M5 x 0.8 depth 7.5	9	7	54	12	M5 x 0.8 depth 11	26	10	5	36	5.5	10
MUB32	5 to 300	26	23.5	28	45	M6 x 1 depth 12	6.5	8	68	14	M6 x 1 depth 11	42	8.5	5.5	40	5.5	12
MUB40	5 to 300	30	27	32	44	M8 x 1.25 depth 13	8	9	86	16	M8 x 1.25 depth 11	54	9	7	45	6	14
MUB50	5 to 300	35	32	39	54	M10 x 1.5 depth 14.5	10	9	104	20	M10 x 1.5 depth 15	64	11.5	8	53	7	18
MUB63	5 to 300	35	32	50	53	M12 x 1.75 depth 18	11	12	124	20	M12 x 1.75 depth 15	72	11.5	10	56	7	18

Model	MM	N	NC	ND	NE	NS	NX	NY	P			S	ZZ	Rod End Female Thread (mm)			
									TN	TF	TF			Model	H	MM	ZZ
MUB25	M10 x 1.25	16.5	7.5 depth 4.5	M5 x 0.8	4.3	43	6	26	M5 x 0.8	—	—	55	91	MUB25	14	M6 x 1 depth 12	69
MUB32	M12 x 1.25	18	9 depth 5.5	M6 x 1	5.1	45	6.5	28	Rc1/8	NPT1/8	G1/8	58	98	MUB32	14	M8 x 1.25 depth 13	72
MUB40	M14 x 1.5	18.5	10.5 depth 6.5	M8 x 1.25	6.9	44	8	36	Rc1/8	NPT1/8	G1/8	60	105	MUB40	15	M8 x 1.25 depth 13	75
MUB50	M18 x 1.5	24	13.5 depth 8.5	M10 x 1.5	8.7	54	10	42	Rc1/4	NPT1/4	G1/4	74	127	MUB50	18	M10 x 1.5 depth 15	92
MUB63	M18 x 1.5	24	17 depth 10.5	M12 x 1.75	10.5	53	11	46	Rc1/4	NPT1/4	G1/4	75	131	MUB63	21	M10 x 1.5 depth 15	96

* The position of the 4 flats of the piston rod is $\pm 3^\circ$ in relation to the cylinder side surface.

Dimensions with Mounting Bracket

Foot

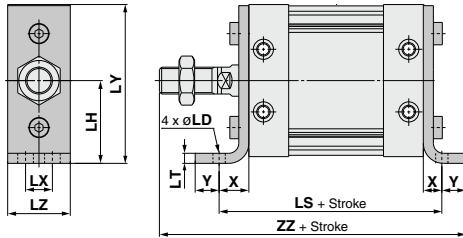

Model	LD	LH	LS	LT	LX	LY	LZ	X	Y	ZZ
MUL25	5.5	29	79	3.2	11	56	23	12	6	109
MUL32	6.6	37	90	4.5	12	71	27	16	8	122
MUL40	9	46	96	4.5	15	89	31	18	10	133
MUL50	11	57	116	5	18	109	37	21	11	159
MUL63	13.5	67	123	6	22	129	48	24	14	169

Foot bracket material: Rolled steel
Surface treatment: Nickel plated

Rod flange

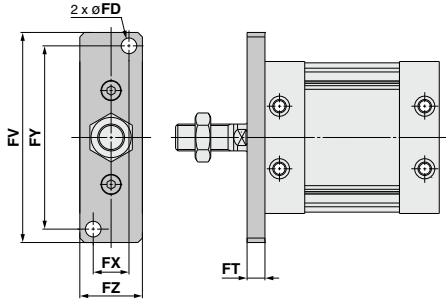

Head flange

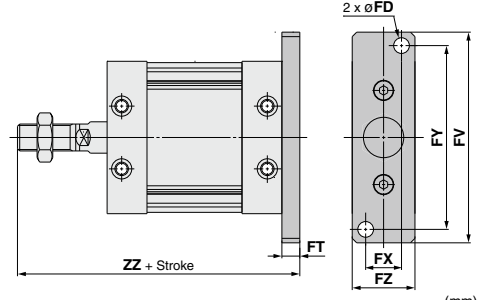

Model	FD	FT	FV	FX	FY	FZ	ZZ
MUF25, MUG25	5.5	8	76	14	66	24	99
MUF32, MUG32	7	8	94	16	82	28	106
MUF40, MUG40	9	9	118	18	102	32	114
MUF50, MUG50	11	12	144	22	126	39	139
MUF63, MUG63	13	14	168	30	148	50	145

Flange bracket material: Carbon steel
Surface treatment: Nickel plated

Single clevis Double clevis

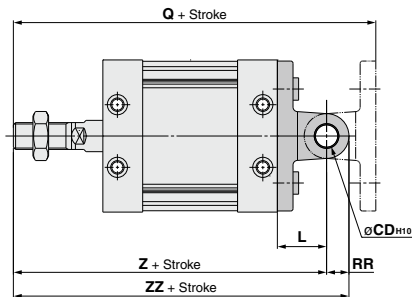

Single clevis

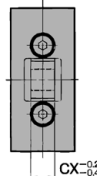
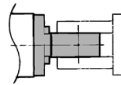

Double clevis

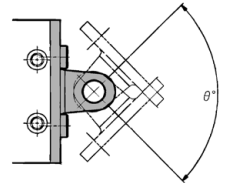
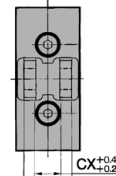
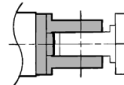

Model	CDH10	CX	CZ	L	Q	RR	Z	ZZ	Rotation range (°)
MUC25, MUD25	8 ^{+0.058}	9	18	17	125	8	108	116	100
MUC32, MUD32	10 ^{+0.058}	11	22	22	142	10	120	130	90
MUC40, MUD40	10 ^{+0.058}	13	26	27	159	10	132	142	80
MUC50, MUD50	14 ^{+0.070}	16	32	32	191	14	159	173	80
MUC63, MUD63	14 ^{+0.070}	16	32	38	207	16	169	185	80

Clevis pin and retaining ring are shipped together with double clevis.

Single/Double clevis material: Cast iron
Surface treatment: Painted

Plate Cylinder: Double Acting, Double Rod

MUW Series

ø25, ø32, ø40, ø50, ø63



How to Order

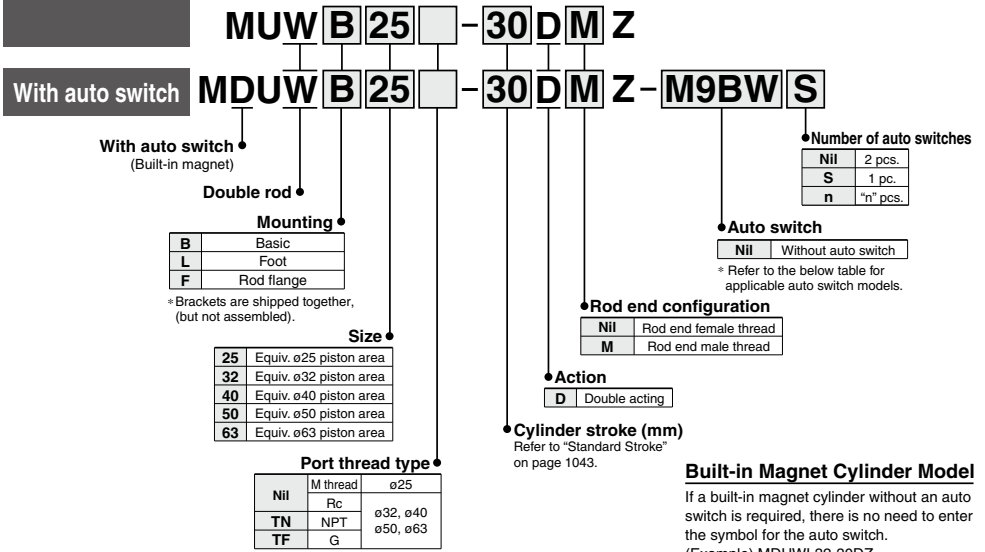

Built-in Magnet Cylinder Model

If a built-in magnet cylinder without an auto switch is required, there is no need to enter the symbol for the auto switch. (Example) MDUWL32-30DZ

Applicable Auto Switches

Refer to pages 1575 to 1701 for further information on auto switches.

Type	Special function	Electrical entry	Indicator light	Wiring (Output)	Load voltage		Auto switch model		Lead wire length (m)			Pre-wired connector	Applicable load	
					DC	AC	Perpendicular	In-line	0.5 (Nil)	1 (M)	3 (L)			5 (Z)
Solid state auto switch	Diagnostic indication (2-color indicator)	Grommet	Yes	3-wire (NPN)	5 V, 12 V	—	M9NV	M9N	●	●	○	○	IC circuit	Relay, PLC
				3-wire (PNP)			M9PV	M9P	●	●	○	○		
				2-wire	M9BV	M9B	●	●	○	○	—			
				3-wire (NPN)	M9NWX	M9NWX	●	●	○	○	IC circuit			
				3-wire (PNP)	M9PWX	M9PWX	●	●	○	○				
				2-wire	M9BWX	M9BWX	●	●	○	○	—			
	Water resistant (2-color indicator)	Grommet	Yes	3-wire (NPN)	5 V, 12 V	—	M9NAV*1	M9NA*1	○	○	●	○	IC circuit	—
				3-wire (PNP)			M9PAV*1	M9PA*1	○	○	●	○		
				2-wire	M9BAV*1	M9BA*1	○	○	●	○	—			
				2-wire (Non-polar)	—	P3DWA ^{Note 2)}	●	—	●	○				
Magnetic field resistant (2-color indicator)	Grommet	Yes	3-wire (NPN equivalent)	—	5 V	—	A96V	A96	●	—	—	IC circuit	—	
			2-wire				A93V*2	A93	●	●	●			—
			2-wire	A90V	A90	●	—	—	—	IC circuit				

*1 Water resistant type auto switches can be mounted on the above models, but in such case SMC cannot guarantee water resistance. Consult with SMC regarding water resistant types with the above model numbers.

*2 1 m type lead wire is only applicable to D-A93.

* Lead wire length symbols: 0.5 m Nil (Example) M9NW
1 m M (Example) M9NWM
3 m L (Example) M9NWL
5 m Z (Example) M9NWX

* Solid state auto switches marked with "○" are produced upon receipt of order.

* For details about auto switches with pre-wired connector, refer to pages 1648 and 1649.

* Auto switches are shipped together, (but not assembled).

Note 1) The D-M9□V/M9□WV/M9□AV/A9□V auto switches cannot be mounted on the ported surface with some cylinder strokes and sizes of fittings. This should be checked beforehand.

Note 2) The magnetic field resistant auto switch (D-P3DWA□) is available the current MU series. Refer to page 1058 for the how-to-order.



Specifications



Bore size (mm)	25	32	40	50	63
Action	Double acting, Double rod				
Fluid	Air				
Proof pressure	1.05 MPa				
Maximum operating pressure	0.7 MPa				
Minimum operating pressure	0.05 MPa				
Ambient and fluid temperature	-10 to 60°C				
Lubrication	Not required (Non-lube)				
Piston speed	50 to 500 mm/s				
Stroke length tolerance	+1.4 0				
Cushion	Rubber bumper				
Mounting	Foot, Rod flange				
Allowable rotational torque	0.25 N-m		0.55 N-m	1.25 N-m	2.0 N-m
Rod non-rotating accuracy	±1°	±0.8°		±0.5°	

Symbol

Rubber bumper (Oval piston)

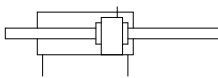

Standard Stroke

Size	Standard stroke (mm)	Maximum manufacturable stroke (mm)
25, 32, 40	5, 10, 15, 20, 25, 30, 35, 40, 45, 50	300
50, 63	75, 100, 125, 150, 175, 200, 250, 300	

* Other intermediate strokes can be manufactured upon receipt of order. Please contact SMC.
** Strokes longer than 300 mm are not available.

Mounting Bracket/Part No.

Mounting bracket	Size				
	25	32	40	50	63
Foot <small>Note 1)</small>	MU-L02	MU-L03	MU-L04	MU-L05	MU-L06
Rod flange	MU-F02	MU-F03	MU-F04	MU-F05	MU-F06

Note 1) When ordering foot bracket, order 2 pieces per cylinder.

Note 2) Body mounting bolts are attached to the foot and rod flange.

Note 3) The tightening torque for body mounting bolts is shown in the below table.

Note 4) The application of a locking agent (Example: Loctite 242) to body mounting bolts is recommended.

Recommended Tightening Torque for Mounting Bracket on Body

Bore size	Thread size	Tightening torque (N-m)
MU25	M5 x 0.8	4.9 to 5.9
MU32	M6 x 1	8.28 to 10.12
MU40	M8 x 1.25	19.8 to 24.2
MU50	M10 x 1.5	39.6 to 48.4
MU63	M12 x 1.75	68.4 to 83.6

Accessory (Option)

For details about the single knuckle joint, double knuckle joint, clevis pin, and knuckle pin, refer to pages 1054 and 1055.

⚠ Warning

When removing or installing a workpiece using rod end threads, do so while securing the width across flats on the removing or installing side. If applying a torque on the piston rod without securing the width across flats, connection threads inside are loosened, which may cause accidents or malfunctions.

Theoretical Output

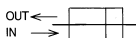

(N)

Size	Rod size (mm)	Operating direction	Piston area (mm ²)	Operating pressure (MPa)					
				0.2	0.3	0.4	0.5	0.6	0.7
25	12	IN/OUT	378	76	113	151	189	227	265
32	14	IN/OUT	650	130	195	260	325	390	455
40	16	IN/OUT	1056	211	317	422	528	634	739
50	20	IN/OUT	1649	330	495	660	824	989	1154
63	20	IN/OUT	2803	561	841	1121	1402	1682	1962

Note) Theoretical output (N) = Pressure (MPa) x Piston area (mm²)

Weight

(kg)

Size		25	32	40	50	63
Basic weight	Basic	0.18	0.31	0.46	0.87	1.34
	Foot	0.25	0.45	0.67	1.21	1.97
	Rod flange	0.28	0.45	0.69	1.33	2.17
Additional weight per each 50 mm of stroke		0.15	0.22	0.29	0.44	0.55
Mounting bracket weight	Single knuckle joint	0.03	0.04	0.07	0.16	0.16
	Double knuckle joint (With pin)	0.05	0.09	0.14	0.29	0.29

Additional Weight

(g)

Bore size (mm)		25	32	40	50	63
Rod end male thread	Male thread	24	46	54	106	106
	Nut	16	20	34	64	64

Calculation:

(Example) **MUWL32-100DZ**

- Basic weight 0.45 (Foot, Equivalent to ø32)
- Additional weight 0.22/50 stroke
- Stroke 100 stroke

$$0.45 + 100/50 \times 0.22 = 0.89 \text{ kg}$$

Construction

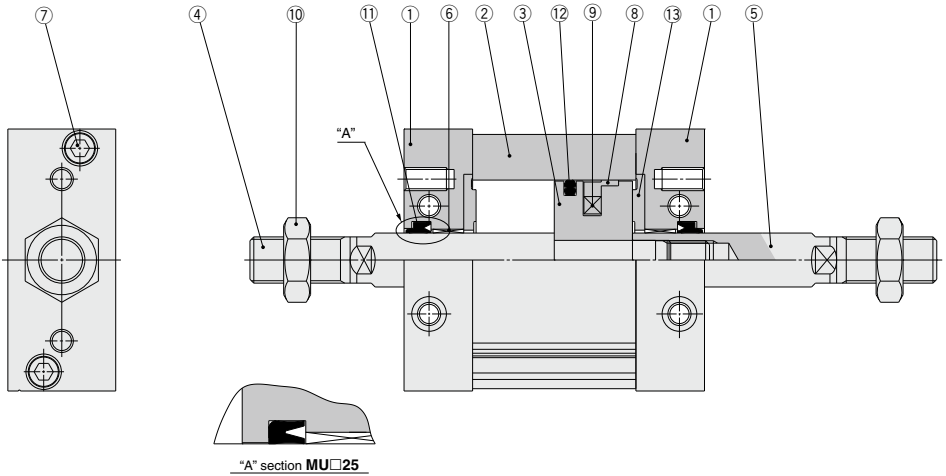

Component Parts

No.	Description	Material	Note
1	Rod cover	Aluminum alloy	Anodized
2	Cylinder tube	Aluminum alloy	Hard anodized
3	Piston	Aluminum alloy	Chromated
4	Piston rod A	Carbon steel	Hard chrome plated
5	Piston rod B	Carbon steel	Hard chrome plated
6	Bushing	Bearing alloy	
7	Hexagon socket head cap screw	Stainless steel	
8	Wear ring	Resin	
9	Magnet	—	Only built-in magnet type
10	Rod end nut	Rolled steel	Only attached to rod end male thread
11	Rod seal	NBR	
12	Piston seal	NBR	
13	Bumper	NBR	

Replacement Parts/Seal Kit

Bore size (mm)	Kit no.	Contents
25	MUW25-PS	Set of nos. above ①, ②, ⑬
32	MUW32-PS	
40	MUW40-PS	
50	MUW50-PS	
63	MUW63-PS	

- * Seal kit includes ① to ⑬. Order the seal kit, based on each bore size.
- * Since the seal kit does not include a grease pack, order it separately.
Grease pack part no.: GR-S-010 (10 g)

CUJ

CU

CQS

JCQ

CQ2

RQ

CQM

CQU

MU

D-□

-X□

Technical Data

MUW Series

Basic: MUWB

Rod end male thread

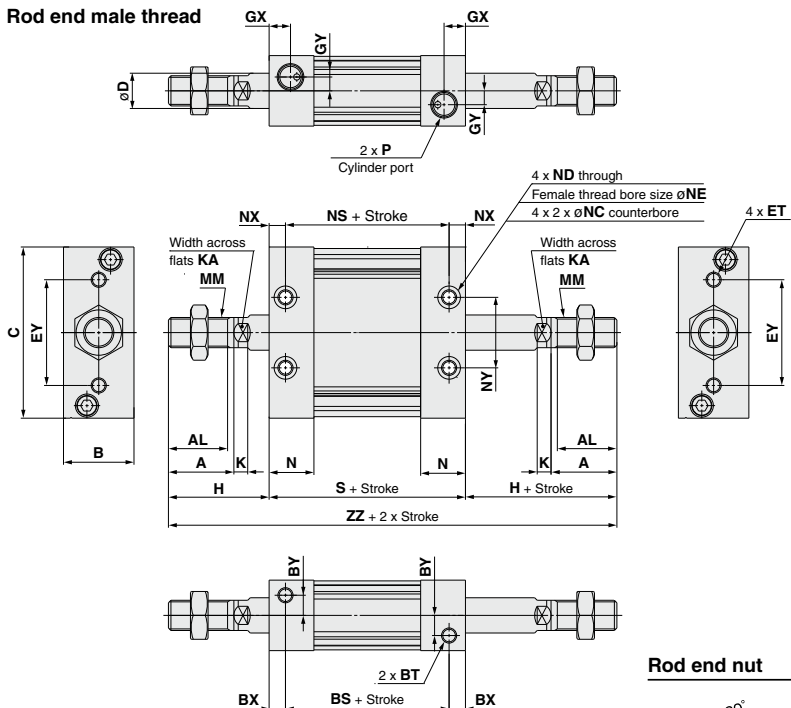

Rod end nut

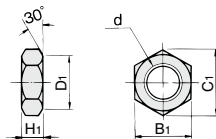

Part no.	Size	d	H ₁	B ₁	C ₁	D ₁
NT-03	25	M10 x 1.25	6	17	19.6	16.5
NT-MU03	32	M12 x 1.25	7	19	21.9	18
NT-04	40	M14 x 1.5	8	22	25.4	21
NT-05	50, 63	M18 x 1.5	11	27	31.2	26

* A nut is attached to the rod end male thread as standard.
Rod end nut material: Carbon steel
Surface treatment: Chromated
(2 pieces for double rod type)

Rod end female thread

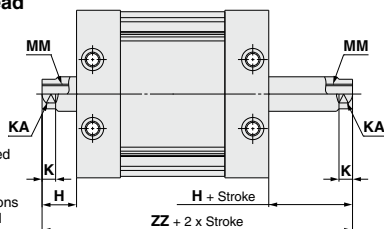

* Dimensions except mentioned on the right are the same as male thread type. However, K and KA dimensions are the same as male thread type.

Model	Stroke range (mm)	A	AL	B	BS	BT	BX	BY	C	D	ET	EY	GX	GY	H	K	KA
MUWB25	5 to 300	22	19.5	24	37	M5 x 0.8 depth 7.5	9	7	54	12	M5 x 0.8 depth 11	26	10	5	36	5.5	10
MUWB32	5 to 300	26	23.5	28	45	M6 x 1 depth 12	6.5	8	68	14	M6 x 1 depth 11	42	8.5	5.5	40	5.5	12
MUWB40	5 to 300	30	27	32	44	M8 x 1.25 depth 13	8	9	86	16	M8 x 1.25 depth 11	54	9	7	45	6	14
MUWB50	5 to 300	35	32	39	54	M10 x 1.5 depth 14.5	10	9	104	20	M10 x 1.5 depth 15	64	11.5	8	53	7	18
MUWB63	5 to 300	35	32	50	53	M12 x 1.75 depth 18	11	12	124	20	M12 x 1.75 depth 15	72	11.5	10	56	7	18

(mm)

Model	MM	N	NC	ND	NE	NS	NX	NY	P			S	ZZ
									—	TN	TF		
MUWB25	M10 x 1.25	16.5	7.5 depth 4.5	M5 x 0.8	4.3	43	6	26	M5 x 0.8	—	—	55	127
MUWB32	M12 x 1.25	18	9 depth 5.5	M6 x 1	5.1	45	6.5	28	Rc1/8	NPT1/8	G1/8	58	138
MUWB40	M14 x 1.5	18.5	10.5 depth 6.5	M8 x 1.25	6.9	44	8	36	Rc1/8	NPT1/8	G1/8	60	150
MUWB50	M18 x 1.5	24	13.5 depth 8.5	M10 x 1.5	8.7	54	10	42	Rc1/4	NPT1/4	G1/4	74	180
MUWB63	M18 x 1.5	24	17 depth 10.5	M12 x 1.75	10.5	53	11	46	Rc1/4	NPT1/4	G1/4	75	187

Rod End Female Thread (mm)

Model	H	MM	ZZ
MUWB25	14	M6 x 1 depth 12	83
MUWB32	14	M8 x 1.25 depth 13	86
MUWB40	15	M8 x 1.25 depth 13	90
MUWB50	18	M10 x 1.5 depth 15	110
MUWB63	21	M10 x 1.5 depth 15	117

* The position of the 4 flats of the piston rod is different from the above drawing. Position of the 4 flats of the piston rod for double rod type is not the same.

Dimensions with Mounting Bracket

Foot

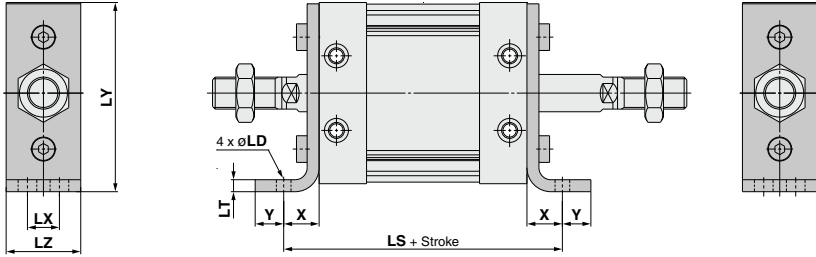

Model	LD	LH	LS	LT	LX	LY	LZ	X	Y
MUWL25	5.5	29	79	3.2	11	56	23	12	6
MUWL32	6.6	37	90	4.5	12	71	27	16	8
MUWL40	9	46	96	4.5	15	89	31	18	10
MUWL50	11	57	116	5	18	109	37	21	11
MUWL63	13.5	67	123	6	22	129	48	24	14

Foot bracket material: Rolled steel
Surface treatment: Nickel plated

Rod flange

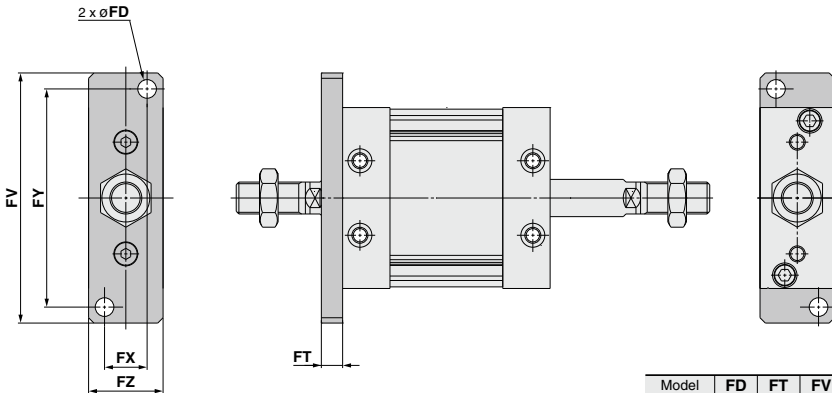

Model	FD	FT	FV	FX	FY	FZ
MUWF25	5.5	8	76	14	66	24
MUWF32	7	8	94	16	82	28
MUWF40	9	9	118	18	102	32
MUWF50	11	12	144	22	126	39
MUWF63	13	14	168	30	148	50

Rod flange bracket material: Carbon steel
Surface treatment: Nickel plated

CUJ

CU

CQS

JCQ

CQ2

RQ

CQM

CQU

MU

D-□

-X□

Technical
Data

Plate Cylinder: Single Acting, Spring Return/Extend

MU Series

ø25, ø32, ø40, ø50, ø63



How to Order

MU B 25 - 10 S M Z

With auto switch MDU B 25 - 10 S M Z - M9BW S

With auto switch (Built-in magnet)

Mounting

B	Basic
L	Foot
F	Rod flange
G	Head flange
C	Single clevis
D	Double clevis

* Brackets are shipped together, (but not assembled).

Size

25	Equiv. ø25 piston area
32	Equiv. ø32 piston area
40	Equiv. ø40 piston area
50	Equiv. ø50 piston area
63	Equiv. ø63 piston area

Port thread type

Nil	M thread	ø25
	Fc	
TN	NPT	ø32, ø40
TF	G	ø50, ø63

Number of auto switches

Nil	2 pcs.
S	1 pc.
n	"n" pcs.

Auto switch

Nil	Without auto switch
------------	---------------------

* Refer to the below table for applicable auto switch models.

Rod end configuration

Nil	Rod end female thread
M	Rod end male thread

Action

S	Single acting, Spring return
T	Single acting, Spring extend

Built-in Magnet Cylinder Model

If a built-in magnet cylinder without an auto switch is required, there is no need to enter the symbol for the auto switch. (Example) MDUL32-10TZ

Cylinder standard stroke (mm)

ø25, ø32	5, 10
ø40, ø50, ø63	5, 10, 15, 20

Applicable Auto Switches

Refer to pages 1575 to 1701 for further information on auto switches.

Type	Special function	Electrical entry	Indicator light	Wiring (Output)	Load voltage		Auto switch model		Lead wire length (m)			Pre-wired connector	Applicable load	
					DC	AC	Perpendicular	In-line	0.5 (Nil)	1 (M)	3 (L)			5 (Z)
Solid state auto switch	—	Grommet	Yes	3-wire (NPN)	5 V, 12 V	—	M9NV	M9N	●	●	●	○	IC circuit	
				3-wire (PNP)			M9PV	M9P	●	●	●	○		
				2-wire	12 V		M9BV	M9B	●	●	●	○		—
				3-wire (NPN)			M9NVW	M9NW	●	●	●	○		
	Diagnostic indication (2-color indicator)			2-wire	5 V, 12 V		M9PWW	M9PW	●	●	●	○	IC circuit	
							3-wire (PNP)	M9BWW	M9BW	●	●	●		○
	Water resistant (2-color indicator)			3-wire (NPN)	5 V, 12 V		M9NAV *1	M9NA *1	○	○	●	○	IC circuit	
							3-wire (PNP)	M9PAV *1	M9PA *1	○	○	●		○
	Magnetic field resistant (2-color indicator)	2-wire	—	M9BAV *1	M9BA *1	○	○	●	○	—				
				2-wire (Non-polar)	—	P3DWA (Note 2)	●	—	●		○			
Reed auto switch	—	Grommet	Yes	3-wire (NPN equivalent)	—	5 V	A96V	A96	●	●	—	—	IC circuit	
				2-wire			24 V	12 V	A93V *2	A93	●	●		●
				None	100 V or less	A90V			A90	●	●	●	—	—

*1 Water resistant type auto switches can be mounted on the above models, but in such case SMC cannot guarantee water resistance. Consult with SMC regarding water resistant types with the above model numbers.

*2 1 m type lead wire is only applicable to D-A93.

* Lead wire length symbols: 0.5 m Nil (Example) M9NW
 1 m M (Example) M9NWM
 3 m L (Example) M9NWL
 5 m Z (Example) M9NWX

* Solid state auto switches marked with "○" are produced upon receipt of order.

* For details about auto switches with pre-wired connector, refer to pages 1648 and 1649.

* Auto switches are shipped together, (but not assembled).

Note 1) The D-M9□V/M9□WV/M9□AV/A9□V auto switches cannot be mounted on the ported surface with some cylinder strokes and sizes of fittings. This should be checked beforehand.

Note 2) The magnetic field resistant auto switch (D-P3DWA□) is available the current MU series. Refer to page 1058 for the how-to-order.



Specifications

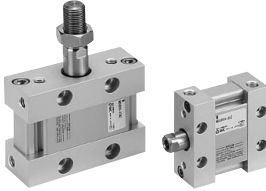

Bore size (mm)	25	32	40	50	63
Action	Single acting, Spring return/Spring extend				
Fluid	Air				
Proof pressure	1.05 MPa				
Maximum operating pressure	0.7 MPa				
Minimum operating pressure	0.18 MPa				
Ambient and fluid temperature	-10 to 60°C				
Lubrication	Not required (Non-lube)				
Piston speed	50 to 500 mm/s				
Stroke length tolerance	+1.4 0				
Cushion	Rubber bumper				
Mounting	Foot, Rod flange, Head flange, Single clevis, Double clevis				
Allowable rotational torque	0.25 N-m		0.55 N-m	1.25 N-m	2.0 N-m
Rod non-rotating accuracy	±1°	±0.8°	±0.5°		

Symbol

Rubber bumper (Oval piston)

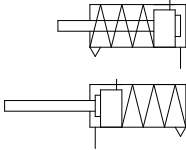

Standard Stroke

Action	Size (mm)				
	25	32	40	50	63
Spring return/Spring extend	5, 10		5, 10, 15, 20		

* For strokes other than above, please contact SMC.

Mounting Bracket/Part No.

Mounting bracket	Size				
	25	32	40	50	63
Foot <small>Note 1)</small>	MU-L02	MU-L03	MU-L04	MU-L05	MU-L06
Flange	MU-F02	MU-F03	MU-F04	MU-F05	MU-F06
Single clevis	MU-C02	MU-C03	MU-C04	MU-C05	MU-C06
Double clevis <small>Note 3)</small>	MU-D02	MU-D03	MU-D04	MU-D05	MU-D06

Note 1) When ordering foot bracket, order 2 pieces per cylinder.

Note 2) Accessories for each mounting bracket are as follows.

Foot/Flange/Single clevis: Body mounting bolt

Double clevis: Clevis pin, Type C retaining ring for axis, Body mounting bolt

Note 3) Clevis pin and retaining ring are shipped together with double clevis.

Note 4) The tightening torque for body mounting bolts is shown in the below table.

Note 5) The application of a locking agent (Example: Loctite 242) to body mounting bolts is recommended.

Recommended Tightening Torque for Mounting Bracket on Body

Bore size	Thread size	Tightening torque (N-m)
MU25	M5 x 0.8	4.9 to 5.9
MU32	M6 x 1	8.28 to 10.12
MU40	M8 x 1.25	19.8 to 24.2
MU50	M10 x 1.5	39.6 to 48.4
MU63	M12 x 1.75	68.4 to 83.6

Accessory (Option)

For details about the single knuckle joint, double knuckle joint, clevis pin, and knuckle pin, refer to pages 1054 and 1055.

CUJ

CU

CQS

JCQ

CQ2

RQ

CQM

CQU

MU

D-□

-X□

Technical
Data

Theoretical Output

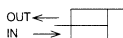

(N)

Action	Size	Rod size (mm)	Operating direction	Piston area (mm ²)	Operating pressure (MPa)						Spring reaction force	
					0.2	0.3	0.4	0.5	0.6	0.7	Secondary	Primary
Spring return	25	12	OUT	491	68	117	166	216	265	314	30	15
	32	14	OUT	804	119	199	280	360	440	521	42	24
	40	16	OUT	1257	195	321	447	573	698	824	56	30
	50	20	OUT	1963	346	542	738	935	1131	1327	76	47
	63	20	OUT	3117	510	822	1134	1446	1757	2069	113	61
Spring extend	25	12	IN	378	46	83	121	159	197	235	30	15
	32	14	IN	650	88	153	218	283	348	413	42	24
	40	16	IN	1056	155	261	366	472	578	683	56	30
	50	20	IN	1649	283	448	613	777	942	1107	76	47
	63	20	IN	2803	448	728	1008	1289	1569	1849	113	61

Note) Theoretical output (N) = Pressure (MPa) x Piston area (mm²)

Weight

(kg)

Size		25	32	40	50	63
Basic weight	5 stroke	0.21	0.26	0.55	1.02	1.51
	10 stroke	0.22	0.34	0.58	1.05	1.56
	15 stroke	—	—	0.60	1.08	1.60
	20 stroke	—	—	0.62	1.12	1.65
Mounting bracket weight	Foot	0.07	0.14	0.21	0.34	0.63
	Flange/Rod end, Head end	0.10	0.14	0.23	0.46	0.83
	Single clevis	0.06	0.12	0.22	0.40	0.68
	Double clevis (With pin)	0.07	0.16	0.26	0.47	0.76
Accessory bracket weight	Single clevis (Double clevis pivot bracket)	0.06	0.12	0.22	0.40	0.68
	Double clevis (With pin) (Single clevis pivot bracket)	0.07	0.16	0.26	0.47	0.76
	Single knuckle joint	0.03	0.04	0.07	0.16	0.16
	Double knuckle joint (With pin)	0.05	0.09	0.14	0.29	0.29

Additional Weight

(g)

Bore size (mm)		25	32	40	50	63
Rod end male thread	Male thread	12	23	27	53	53
	Nut	8	10	17	32	32

Note) Weight of single clevis and double clevis includes 2 bolts for mounting bracket.

Calculation:

(Example 1) **MUB40-15S(T)Z**

- Basic weight 0.60 kg

(Example 2) **MUC50-5S(T)Z**

- Basic weight 1.02
- Mounting bracket weight 0.40

$$1.02 + 0.40 = 1.42 \text{ kg}$$

Construction

Spring return

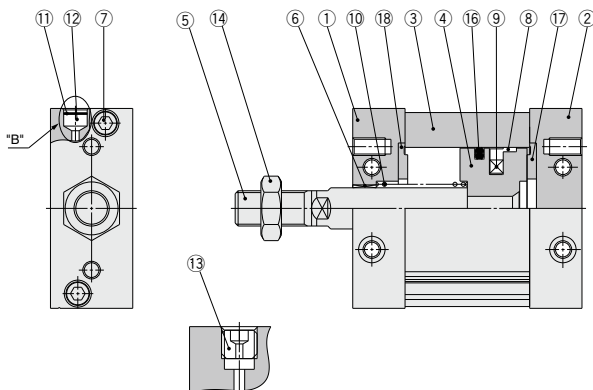

"B" section MU□25

Spring extend

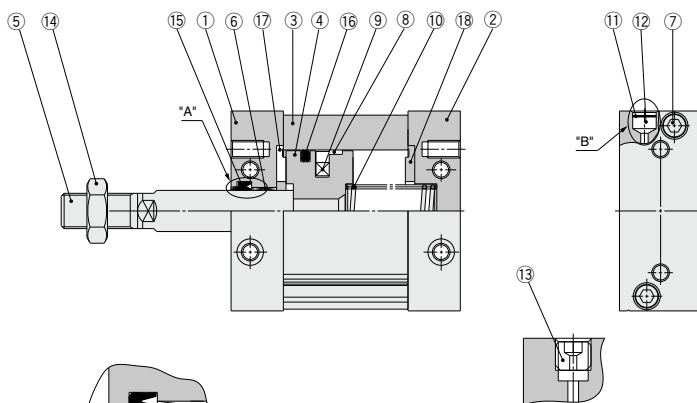

"A" section MU□25

"B" section MU□25

Component Parts

No.	Description	Material	Note
1	Rod cover	Aluminum alloy	Anodized
2	Head cover	Aluminum alloy	Anodized
3	Cylinder tube	Aluminum alloy	Hard anodized
4	Piston	Aluminum alloy	Chromated
5	Piston rod	Carbon steel	Hard chrome plated
6	Bushing	Bearing alloy	
7	Hexagon socket head cap screw	Stainless steel	
8	Wear ring	Resin	
9	Magnet	—	Only built-in magnet type
10	Return spring	Steel wire	Zinc chromated
11	Element	Bronze	
12	Retaining ring	Spring steel	
13	Plug	Chromium molybdenum steel	
14	Rod end nut	Rolled steel	Only attached to rod end male thread
15	Rod seal	NBR	
16	Piston seal	NBR	
17	Bumper	Urethane	
18	Bumper B	Urethane	

Replacement Parts/Seal Kit

Bore size (mm)	Kit no.		Contents
	Spring return	Spring extend	
25	MU25S-PS	MU25T-PS	For spring return type: 15, 17, 18 as a set For spring extend type: 15, 16, 17, 18 as a set
32	MU32S-PS	MU32T-PS	
40	MU40S-PS	MU40T-PS	
50	MU50S-PS	MU50T-PS	
63	MU63S-PS	MU63T-PS	

* Seal kit includes 15, 16, 17, 18 (excluding 15 for spring return type). Order them with a part number for each bore size.

* Since the seal kit does not include a grease pack, order it separately.

Grease pack part no.: GR-S-010 (10 g)

CUJ

CU

CQS

JCQ

CQ2

RQ

CQM

CQU

MU

D-□

-X□

Technical Data

MU Series

Basic

Spring return

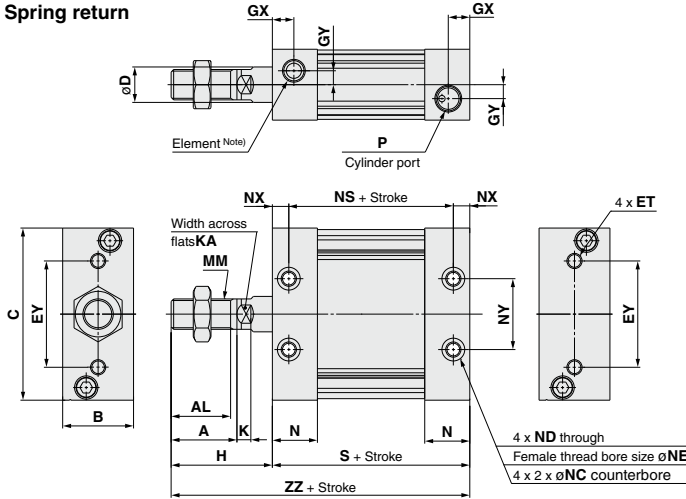

Rod end female thread

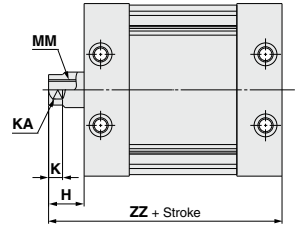

• Dimensions except 1 mentioned above are the same as male thread type. However, K and KA dimensions are the same as male thread type.

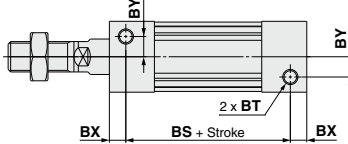

Spring extend

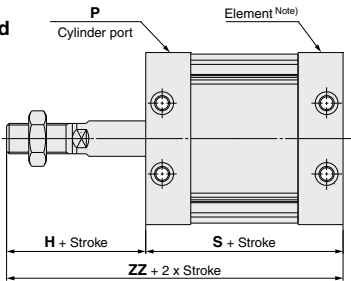

(Note) Plugged for the MUB25

Rod end nut

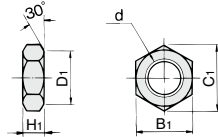

Part no.	Size	d	H ₁	B ₁	C ₁	D ₁
NT-03	25	M10 x 1.25	6	17	19.6	16.5
NT-MU03	32	M12 x 1.25	7	19	21.9	18
NT-04	40	M14 x 1.5	8	22	25.4	21
NT-05	50, 63	M18 x 1.5	11	27	31.2	26

• A nut is attached to the rod end nut material: Carbon steel
Surface treatment: Chromated

Model	Standard stroke (mm)	A	AL	B	BS	BT	BX	BY	C	D	ET	EY	GX	GY	H	K	KA
MUB25	5, 10	22	19.5	24	42	M5 x 0.8 depth 7.5	9	7	54	12	M5 x 0.8 depth 11	26	10	5	36	5.5	10
MUB32	5, 10	26	23.5	28	50	M6 x 1 depth 12	6.5	8	68	14	M6 x 1 depth 11	42	8.5	5.5	40	5.5	12
MUB40	5, 10, 15, 20	30	27	32	54	M8 x 1.25 depth 13	8	9	86	16	M8 x 1.25 depth 11	54	9	7	45	6	14
MUB50	5, 10, 15, 20	35	32	39	64	M10 x 1.5 depth 14.5	10	9	104	20	M10 x 1.5 depth 15	64	11.5	8	53	7	18
MUB63	5, 10, 15, 20	35	32	50	63	M12 x 1.75 depth 18	11	12	124	20	M12 x 1.75 depth 15	72	11.5	10	56	7	18

Model	MM	N	NC	ND	NE	NS	NX	NY	P			S	ZZ
									TN	TF	TF		
MUB25	M10 x 1.25	16.5	7.5 depth 4.5	M5 x 0.8	4.3	48	6	26	M5 x 0.8	—	—	60	96
MUB32	M12 x 1.25	18	9 depth 5.5	M6 x 1	5.1	50	6.5	28	Rc1/8	NPT1/8	G1/8	63	103
MUB40	M14 x 1.5	18.5	10.5 depth 6.5	M8 x 1.25	6.9	54	8	36	Rc1/8	NPT1/8	G1/8	70	115
MUB50	M18 x 1.5	24	13.5 depth 8.5	M10 x 1.5	8.7	64	10	42	Rc1/4	NPT1/4	G1/4	84	137
MUB63	M18 x 1.5	24	17 depth 10.5	M12 x 1.75	10.5	63	11	46	Rc1/4	NPT1/4	G1/4	85	141

Rod End Female Thread (mm)

Model	H	MM	ZZ
MUB25	14	M6 x 1 depth 12	74
MUB32	14	M8 x 1.25 depth 13	77
MUB40	15	M8 x 1.25 depth 13	85
MUB50	18	M10 x 1.5 depth 15	102
MUB63	21	M10 x 1.5 depth 15	106

* The position of the 4 flats of the piston rod is $\pm 3^\circ$ in relation to the cylinder side surface.

Dimensions with Mounting Bracket

Foot

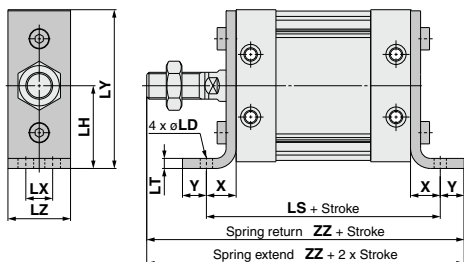

Model	LD	LH	LS	LT	LX	LY	LZ	X	Y	ZZ
MUL25	5.5	29	84	3.2	11	56	23	12	6	114
MUL32	6.6	37	95	4.5	12	71	27	16	8	127
MUL40	9	46	106	4.5	15	89	31	18	10	143
MUL50	11	57	126	5	18	109	37	21	11	169
MUL63	13.5	67	133	6	22	129	48	24	14	179

Foot bracket material: Rolled steel
Surface treatment: Nickel plated

Rod flange

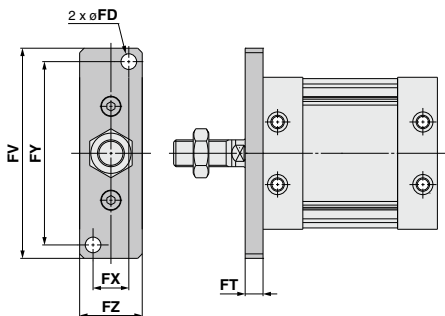

Head flange

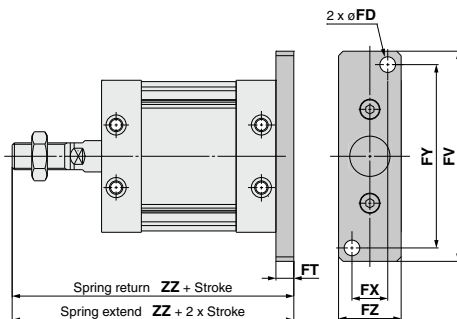

Model	FD	FT	FV	FX	FY	FZ	ZZ
MUF25, MUG25	5.5	8	76	14	66	24	104
MUF32, MUG32	7	8	94	16	82	28	111
MUF40, MUG40	9	9	118	18	102	32	124
MUF50, MUG50	11	12	144	22	126	39	149
MUF63, MUG63	13	14	168	30	148	50	155

Flange bracket material: Carbon steel
Surface treatment: Nickel plated

Single clevis

Double clevis

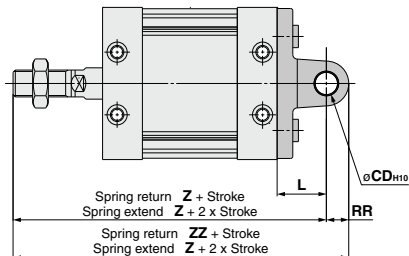

Single clevis

Double clevis

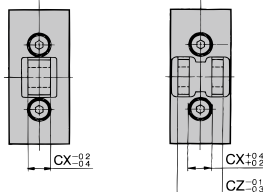

Model	CDH10	CX	CZ	L	RR	Z	ZZ
MUC25, MUD25	$8^{+0.058}_0$	9	18	17	8	113	121
MUC32, MUD32	$10^{+0.058}_0$	11	22	22	10	125	135
MUC40, MUD40	$10^{+0.058}_0$	13	26	27	10	142	152
MUC50, MUD50	$14^{+0.070}_0$	16	32	32	14	169	183
MUC63, MUD63	$14^{+0.070}_0$	16	32	38	16	179	185

Clevis pin and retaining ring are shipped together with double clevis.

Single/Double clevis material: Cast iron
Surface treatment: Painted

MU Series Accessory Bracket Dimensions

Single Clevis (Double clevis pivot bracket)

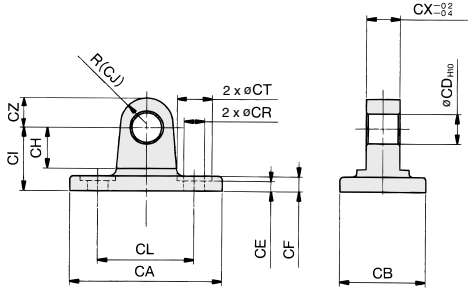

(mm)

Part no.	Size	CA	CB	CDH10	CE	CF	CH	CI	CJ
MU-C02	25	53	23	$8^{+0.058}_0$	3.5	4	11	17	7
MU-C03	32	67	27	$10^{+0.058}_0$	3.5	7	13	22	10
MU-C04	40	85	31	$10^{+0.058}_0$	3.5	10	13	27	10
MU-C05	50	103	37	$14^{+0.070}_0$	5.5	12	17	32	14
MU-C06	63	122	48	$14^{+0.070}_0$	6	14	19	38	16

Part no.	CL	CR	CT	CX	CZ
MU-C02	26	5.3	9.5	9	8
MU-C03	42	6.4	11	11	10
MU-C04	54	8.4	14	13	10
MU-C05	64	10.5	17	16	14
MU-C06	72	13	20	16	16

Material: Cast iron
Surface treatment: Painted

Double Clevis (Single clevis pivot bracket)

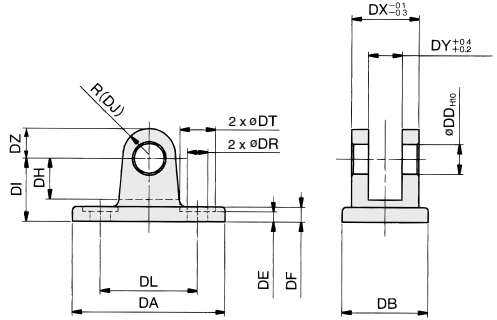

(mm)

Part no.	Size	DA	DB	DDH10	DE	DF	DH	DI	DJ
MU-D02	25	53	23	$8^{+0.058}_0$	3.5	4	11	17	7
MU-D03	32	67	27	$10^{+0.058}_0$	3.5	7	13	22	10
MU-D04	40	85	31	$10^{+0.058}_0$	3.5	10	13	27	10
MU-D05	50	103	37	$14^{+0.070}_0$	5.5	12	17	32	14
MU-D06	63	122	48	$14^{+0.070}_0$	6	14	19	38	16

Part no.	DL	DR	DT	DX	DY	DZ	Applicable pin
MU-D02	26	5.3	9.5	18	9	8	CD-MU02
MU-D03	42	6.4	11	22	11	10	CD-MU03
MU-D04	54	8.4	14	26	13	10	CD-MU04
MU-D05	64	10.5	17	32	16	14	CD-MU05
MU-D06	72	13	20	32	16	16	CD-MU05

Material:
Cast iron
Surface
treatment:
Painted

Clevis pin and retaining ring are attached to double clevis.

Single Knuckle Joint

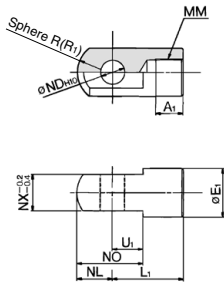

(mm)

Part no.	Size	A1	E1	L1	MM
I-MU02	25	10.5	16	27	M10 x 1.25
I-MU03	32	12	18	31	M12 x 1.25
I-MU04	40	14	20	36	M14 x 1.5
I-MU05	50, 63	18	28	46	M18 x 1.5

Part no.	NDH10	NL	NO	NX	R1	U1
I-MU02	$8^{+0.058}_0$	8.5	19.5	9	8.5	11
I-MU03	$10^{+0.058}_0$	10	24	11	10	14
I-MU04	$10^{+0.058}_0$	11	26	13	11	15
I-MU05	$14^{+0.070}_0$	16	36	16	16	20

Material: Rolled steel
Surface treatment: Nickel plated

Double Knuckle Joint

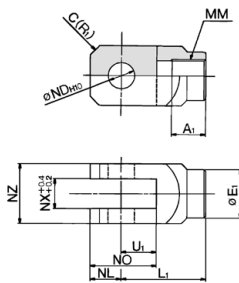

(mm)

Part no.	Size	A1	E1	L1	MM	NDH10
Y-MU02	25	10.5	14	27	M10 x 1.25	$8^{+0.058}_0$
Y-MU03	32	12	18	31	M12 x 1.25	$10^{+0.058}_0$
Y-MU04	40	14	20	36	M14 x 1.5	$10^{+0.058}_0$
Y-MU05	50, 63	18	28	46	M18 x 1.5	$14^{+0.070}_0$

Part no.	NL	NO	NX	NZ	R1	U1	Applicable pin
Y-MU02	8	21	9	18	3	13	CD-MU02
Y-MU03	10	24	11	22	4	14	CD-MU03
Y-MU04	10	27	13	26	5	17	CD-MU04
Y-MU05	16	39	16	32	6	23	CD-MU05

* Knuckle pin and retaining ring are included.

Material: Rolled steel
Surface treatment: Chromated

Clevis Pin/Knuckle Pin

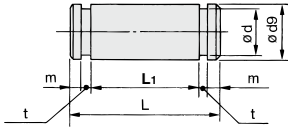

(mm)

Part no.	Size	Dd9	L	d	L ₁	m	t	Retaining ring
CD-MU02	25	8 ^{-0.040} _{-0.076}	23	7.6	18.2	1.5	0.9	Type C8 for axis
CD-MU03	32	10 ^{-0.040} _{-0.076}	27	9.6	22.2	1.25	1.15	Type C10 for axis
CD-MU04	40	10 ^{-0.040} _{-0.076}	31	9.6	26.2	1.25	1.15	Type C10 for axis
CD-MU05	50, 63	14 ^{-0.060} _{-0.096}	38	13.4	32.2	1.75	1.15	Type C14 for axis

* These are provided as standard for double clevis and double knuckle joint.

Material: Carbon steel

** Type C retaining rings for axis are attached.

CUJ

CU

CQS

JCQ

CQ2

RQ

CQM

CQU

MU

D-□

-X□

Technical
Data

MU Series

Auto Switch Mounting 1

Auto Switch Proper Mounting Position (Detection at stroke end) and Mounting Height

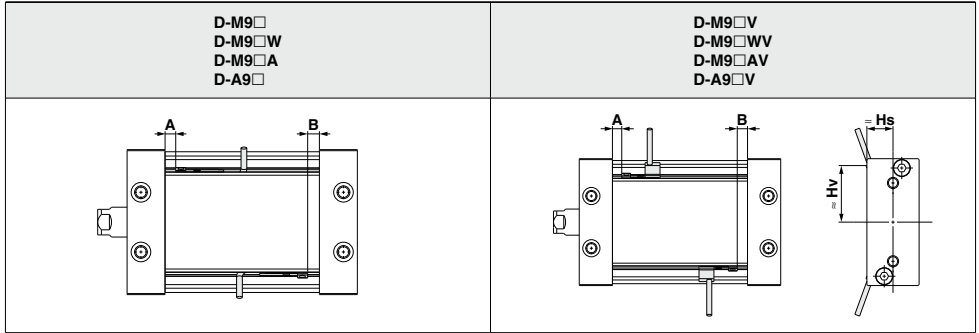

Size	D-M9□ D-M9□W D-M9□A		D-M9□V D-M9□WV D-M9□AV				D-A9□		D-A9□V			
	A	B	A	B	Hs	Hv	A	B	A	B	Hs	Hv
25	5	5	5	5	7.5	27.5	1	1	1	1	—	—
32	5	5	5	5	14.5	30	1	1	1	1	—	—
40	5.5	5.5	5.5	5.5	16.5	37	1.5	1.5	1.5	1.5	—	—
50	7	7	7	7	—	—	3	3	3	3	—	—
63	7.5	7.5	7.5	7.5	—	—	3.5	3.5	3.5	3.5	—	—

Note) Adjust the auto switch after confirming the operating conditions in the actual setting.

Minimum Stroke for Auto Switch Mounting

Number of auto switches mounted	D-M9□ D-M9□W D-M9□A D-A9□	D-M9□V	D-M9□WV D-M9□AV	D-A9□V
1	10	5	10	5
2	10	5	10	10

Note) Consult SMC for shorter stroke length than indicated in the table.

Operating Range

Auto switch model	Size				
	25	32	40	50	63
D-M9□/M9□V D-M9□W/M9□WV D-M9□A/M9□AV	5.5	5.5	5.5	5	5
D-A9□/A9□V	7.5	8	8	7	6.5

* Since the operating range is provided as a guideline including hysteresis, it cannot be guaranteed. (assuming approx. ±30% dispersion)
It may vary substantially depending on the ambient environment.

Mounting and Moving Method of Auto Switch

A Stroke of 20 or less

1. First insert the auto switch into the switch groove.
2. Then, press the auto switch mounting bracket into the switch groove.

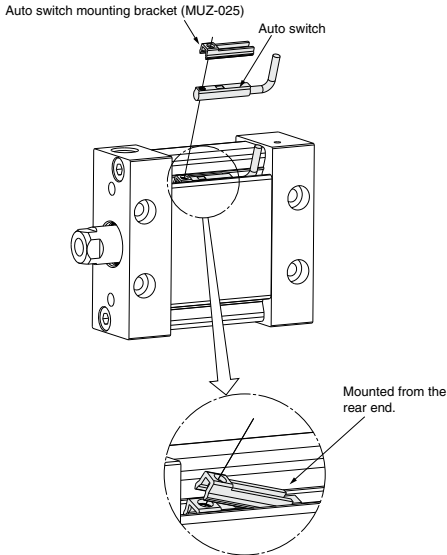

* The auto switch mounting bracket should be mounted from the rear end.

3. Confirm where the mounting position is, and tighten the auto switch mounting screw using a flat head screwdriver to fix the auto switch.

B Stroke of 25 or more

1. First press the auto switch mounting bracket into the switch groove.
2. Then, insert the auto switch into the switch groove, and slide it onto the auto switch mounting bracket.

* Slide the end of the auto switch under the auto switch mounting bracket.

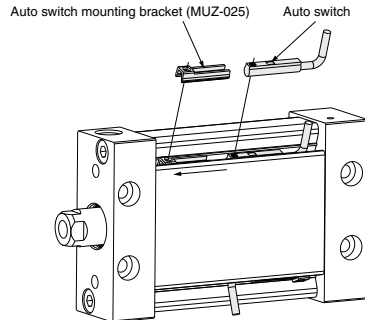

3. Confirm where the mounting position is, and tighten the auto switch mounting screw using a flat head screwdriver to fix the auto switch.

Auto Switch Mounting Bracket Part No.

Cylinder series	Applicable bore size (mm)				
	25	32	40	50	63
MU□-□□Z	MUZ-025				

Note 1) For strokes of 25 or more, mounting method A is also possible.

Note 2) When tightening the auto switch mounting screw, use a watchmaker's screwdriver with the handle diameter of about 5 to 6 mm.

The tightening torque of the mounting screw should be approx. 0.05 to 0.1 N·m.
As a guide, turn an additional 90 degree from the position where it feels tight.

CUJ

CU

CQS

JCQ

CQ2

RQ

CQM

CQU

MU

D-□

-X□

Technical
Data

Auto Switch Mounting 2

Mounting of Magnetic Field Resistant Auto Switch (D-P3DWA, D-P4DW□ series)

When the magnetic field resistant auto switch (D-P3DWA, D-P4DW□ series) is mounted, the current MU series are available. Please pay attention to part no.

How to Order

MDU B 40 - 30 D M - P3DWASC

- With auto switch** (Built-in magnet)
- Mounting**

B	Basic
L	Axial foot
F	Rod flange
G	Head flange
C	Single clevis
D	Double clevis

* Brackets are shipped together, (but not assembled).
- Size**

25	Equiv. ø25 piston area
32	Equiv. ø32 piston area
40	Equiv. ø40 piston area
50	Equiv. ø50 piston area
63	Equiv. ø63 piston area
- Port thread type**

Nil	M thread	ø25
	Rc	ø32, ø40
TN	NPT	ø50, ø63
TF	G	
- Auto switch**

Nil	None
-----	------

* For auto switch model, refer to "How to order the auto switch independently."
- Number of auto switches**

Nil	2 pcs.
S	1 pc.
n	"n" pcs.

* When cylinders/actuators are ordered with an auto switch, the cylinder/actuator, auto switch and auto switch mounting bracket (including screws) are enclosed.
* When the auto switch is ordered on its own, the auto switch mounting bracket is not included. In that case, please order it separately.
- Rod end configuration**

Nil	Rod end female thread
M	Rod end male thread
- Action**

D	Double acting
---	---------------
- Cylinder stroke (mm)**
Refer to "Standard Stroke" on page 1037.



How to order the auto switch independently

D-P3DWA SC

- Lead wire length**

SC	0.3 m (M12 connector type: 3 to 4 pins)
SE	0.3 m (M12 connector type: 1 to 4 pins)
Nil*	0.5 m
L	3 m
Z	5 m

* 0.5 m (Nil) is not available for D-P4DW□.

Auto Switch Proper Mounting Position (Detection at stroke end) and Mounting Height

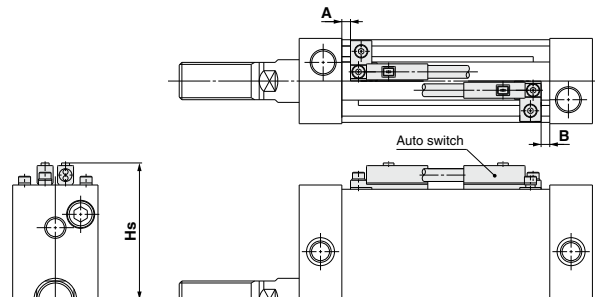

Bore size (mm)	D-P3DWA			D-P4DW		
	A	B	Hs	A	B	Hs
25	2.5	3	37.5	—	—	—
32	2.5	3	44.5	—	—	—
40	3	3.5	52.5	0.5 (5.5)	1 (5.5)	56.5
50	4.5	5	62	2 (7)	2.5 (7.5)	66
63	5	5.5	72	2.5 (7.5)	3 (8)	76

Minimum Stroke for Auto Switch Mounting

Number of auto switches mounted	D-P3DWA		D-P4DW	
	Same surface	Different surfaces	Same surface	Different surfaces
1	15		20	
2	15		75	20

Auto Switch Operating Range

Auto switch model	Bore size (mm)				
	25	32	40	50	63
D-P3DWA	6	6.5	6	6	6
D-P4DW	—	—	5	5	5

* Since the operating range is provided as a guideline including hysteresis, it cannot be guaranteed. (assuming approx. ±30% dispersion)
It may vary substantially depending on the ambient environment.

Mounting and Moving Method of Auto Switch

<Applicable auto switch>

Solid state.....D-P3DWA□

1. Insert the auto switch mounting nut into the groove on the auto switch mounting rail.
2. Remove the hexagon socket head cap screw (M2.5) that is attached to the auto switch. Mount the auto switch mounting bracket (pressed stainless steel bracket) on the auto switch and tighten the hexagon socket head cap screw (M2.5) you have removed 3 to 4 turns to temporarily mount the bracket.
3. Put the spring washer through the hexagon socket head cap screw (M3), and then put the screw through the hole in the flange of the auto switch mounting bracket (pressed stainless steel bracket). Screw it into the M3 tapped part of the auto switch mounting nut and tighten it 3 to 4 turns to temporarily mount the auto switch.
4. After checking the detection position, tighten each hexagon socket head cap screw firmly.
5. Modification of the detection position should be made in the condition of 3.

Note 1) The tightening torque for a hexagon socket head cap screw (M2.5) is 0.2 to 0.3 N·m. Hold the shorter side of a hexagon wrench, and turn it to tighten. (Too much tightening may break the switch)

Note 2) The tightening torque for a hexagon socket head cap screw (M3) is 0.5 to 0.7 N·m.

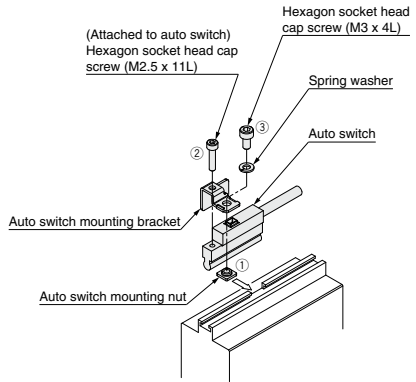

Auto Switch Mounting Bracket Part No. (Including Bracket, Bolt, Nut)

Bore size (mm)				
25	32	40	50	63
BMU4-040S				

Solid state.....D-P4DW□

1. From the cutoff part of the rail on the cylinder body, insert the auto switch mounting nuts (2 pcs.) into the rail groove.
2. Slide the auto switch mounting nuts (2 pcs.) and set into the auto switch mounting position roughly. (25 mm or more should be left for the distance between 2 nuts.)
3. Insert the convex portion of the auto switch mounting bracket into the concave portion of a rail groove. Through-hole for the auto switch mounting bracket should be placed on the auto switch mounting nut.
4. Put a flat washer (ø8 x ø3.3) through a hexagon socket head screw (with spring washer, M3 x 0.5 x 5L) and passing through the hole of an auto switch mounting bracket, then turning it lightly down to a mounting nut of auto switch. (2 locations)
5. Put a round head Phillips screw (with spring washer, M3 x 0.5 x 14L) through the auto switch's through-hole (2 locations), and then push it down into the M3 tapped part on the auto switch mounting bracket while turning it lightly.
6. After reconfirming the detecting position, tighten the auto switch mounting screw to secure the auto switch mounting bracket and the auto switch. (Tightening torque of M3 screw should be 0.5 to 0.7 N·m.)

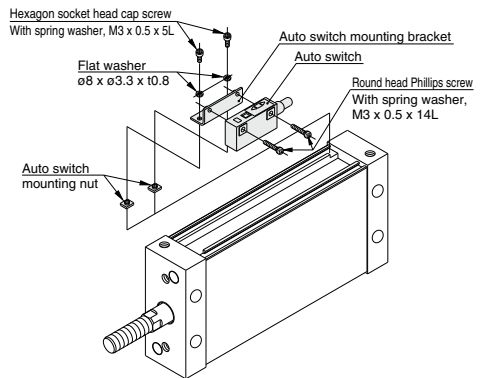

Auto Switch Mounting Bracket Part No. (Including bracket, screw)

Cylinder series	Applicable bore size (mm)		
	40	50	63
MDU	BMU2-040	BMU2-040	BMU2-040
MDLU			—

CUJ

CU

CQS

JCQ

CQ2

RQ

CQM

CQU

MU

D-□

-X□

Technical Data



MU Series

Specific Product Precautions

Be sure to read this before handling the products.

Refer to back page 50 for Safety Instructions and pages 3 to 7 for Actuator Precautions.

Mounting

⚠ Caution

- When a workpiece is secured to the end of the piston rod, ensure that the piston rod is retracted entirely, and place a wrench on the portion of the rod that protrudes beyond the section. Also, tighten in a way that prevents the tightening torque from being applied to the non-rotating guide.

Allowable Torque for Mounting Workpiece (N·m)

Size	25	32	40	50	63
Allowable torque for mounting workpiece	1.7	1.9	2.0	4.9	7.3

- Operate in such a way that the load to the piston rod is always applied in the axial direction. Furthermore, avoid operations that could apply rotational torque to the piston rod. If rotational torque must be applied due to unavoidable circumstances, make sure the allowable rotational torque is not exceeded.
- Operating the cylinder by connecting the piping directly to the cylinder can cause the piston speed to exceed the maximum operating speed of 500 mm/s. Therefore, to operate the cylinder, make sure to use an SMC speed controller and adjust the piston speed to 500 mm/s or less.

Handling of Auto Switches

Be sure to read this before handling the products.
Refer to pages 8 to 12 for Auto Switch Precautions.

⚠ Warning

- If multiple cylinders are operated adjacent to each other, the magnets that are enclosed in the adjacent cylinders could affect the operation of the auto switches, causing the switches to malfunction. Therefore, make sure that the mounting pitch of the cylinders is at least that indicated in the below table.

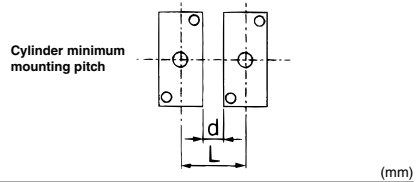

Size	ø25	ø32	ø40	ø50	ø63
L (d)	29 (5)	33 (5)	37 (5)	39 (0)	50 (0)

If cylinders are used with a mounting pitch less than shown above, they must be shielded with iron plates or the separately sold magnetic shielding plate (part no.: MU-S025). Please contact SMC for further information.

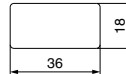

Material: Ferrite stainless steel Thickness: 0.3 mm
Since the back side is treated with adhesive, it can be attached to the cylinder.

How to use

In order not to influence the auto switch mounted on cylinder B adjacent to the magnetic force of cylinder A, use a shielding plate to block the magnetic force.

