

FEMALE END VIEW

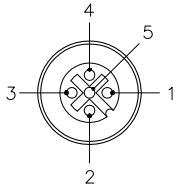

SPECIFICATIONS

CONTACT CARRIER MATERIAL	NYLON or TPU
CONTACT MATERIAL/PLATING	BRASS/GOLD
HOUSING, LOCKNUT MATERIAL/PLATING	BRASS/NICKEL
O-RING MATERIAL	NITRILE
RATED CURRENT [A]	4.0 A
RATED VOLTAGE [V]	250 V
NUMBER OF CONDUCTORS [AWG]	SOLDER LUGS 5x20 AWG MAX.
TEMPERATURE RATING	-40°C to +105°C (-40°F to +221°F)
PROTECTION CLASS	MEETS NEMA 1,3,4,6P AND IEC IP68

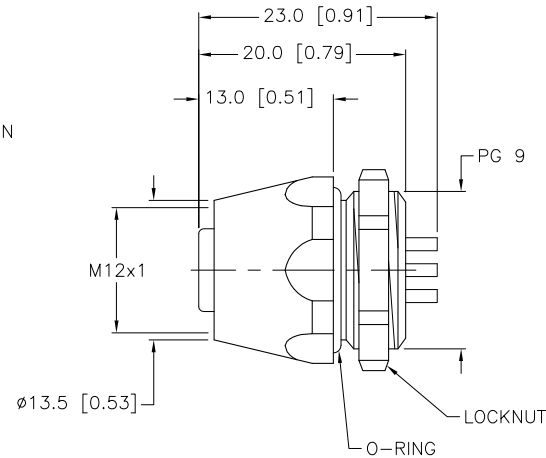
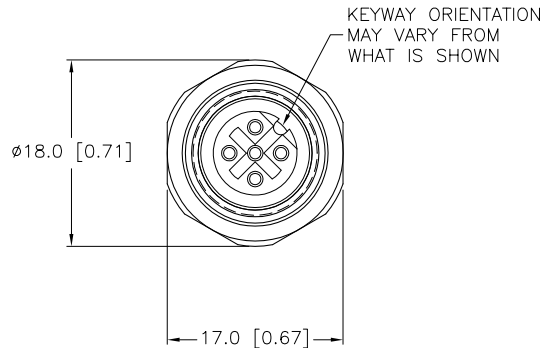

SOURCE DRAWING - FOR REFERENCE ONLY

CABLE LENGTH	TOLERANCE
ALL LENGTHS	+ 4% (OR 50mm) OF LENGTH - 0% (OR 0mm) OF LENGTH WHICHEVER IS GREATER
STRIP LENGTH	TOLERANCE
0-7mm	±0.5mm
8-29mm	±1.0mm
30-49mm	±2.0mm
50-69mm	±3.0mm
70-100mm	±4.0mm
OVER 100mm	±5.0mm

RELATED DOCUMENTS 1. 2. 3. 4.	3RD ANGLE PROJECTION	THIS DRAWING IS PROPERTY OF TURCK INC. USE OF THIS DOCUMENT WITHOUT WRITTEN PERMISSION IS PROHIBITED.			3000 CAMPUS DRIVE MINNEAPOLIS, MN 55441 1-800-544-7769 (763) 553-7300 (763) 553-0708 fax turck.com
			DRFT CK	DATE 02/23/11	DESCRIPTION FK 4.5
MATERIAL SEE SPECIFICATIONS	ALL DIMENSIONS DISPLAYED ON THIS DRAWING ARE FOR REFERENCE ONLY	DSGN	SCALE 1=.8	IDENTIFICATION NO. U1117-4	
FINISH SEE SPECIFICATIONS		UNIT OF MEASUREMENT MILLIMETER [INCH]		REV A	
DO NOT SCALE THIS DRAWING		FILE: U1117-4		SHEET 1 OF 1	

A	DRAWING RELEASE	RDS	03/04/11	
REV	DESCRIPTION	BY	DATE	ECO NO.