

FEMALE END VIEW	MALE END VIEW	WIRING DIAGRAM	SPECIFICATIONS	
 <p>1 = BROWN 3 = BLUE 4 = BLACK</p>	 <p>1 = BROWN 3 = BLUE 4 = BLACK</p>	 <p>1 = VOLTAGE (+) (GREEN) 3 = COMMON (-) 4 = OUTPUT (YELLOW)</p>	CONTACT CARRIER MATERIAL	NYLON OR TPU
			MOLDED HEAD MATERIAL/COLOR (P1)	TPU/CLEAR
			MOLDED HEAD MATERIAL/COLOR (J1)	TPU/YELLOW
			CONTACT MATERIAL/PLATING	BRASS/GOLD
			COUPLING NUT MATERIAL/PLATING (P1)	BRASS/NICKEL
			LOCKING SLEEVE MATERIAL (J1)	POM, SNAP LOCK
			RATED CURRENT [A]	4.0 A
			RATED VOLTAGE [V]	10-30 VDC
			OUTER CABLE JACKET MATERIAL/COLOR	PVC/YELLOW
			CONDUCTOR INSULATION MATERIAL	PVC
			NUMBER OF CONDUCTORS [AWG]	3x24 AWG
			TEMPERATURE RANGE	-40°C to +105°C (-40°F to +221°F)
			PROTECTION CLASS	MEETS NEMA 1,3,4,6P AND IEC IP67

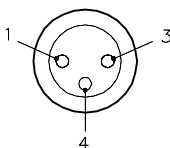
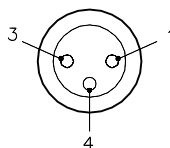
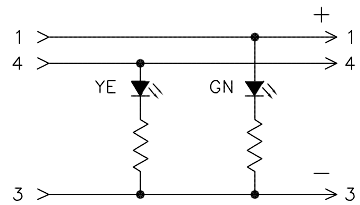
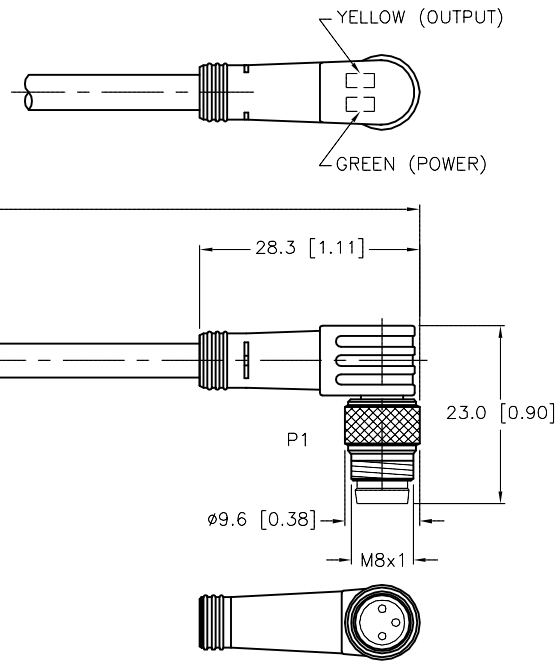

CABLE LENGTH	TOLERANCE *
ALL LENGTHS	+ 4% (OR 50mm) OF LENGTH - 0% (OR 0mm) OF LENGTH WHICHEVER IS GREATER
STRIP LENGTH	TOLERANCE *
0-7mm	±0.5mm
8-29mm	±1.0mm
30-49mm	±2.0mm
50-69mm	±3.0mm
70-100mm	±4.0mm
OVER 100mm	±5.0mm

\* UNLESS OTHERWISE SPECIFIED

NOTES:  
1. "\*" INDICATES CABLE LENGTH IN METERS. CONTACT TURCK TO ORDER SPECIFIC LENGTHS.

SOURCE DRAWING - FOR REFERENCE ONLY

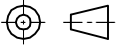
RELATED DOCUMENTS	3RD ANGLE PROJECTION	THIS DRAWING IS CONFIDENTIAL AND THE PROPERTY OF TURCK INC. USE OF THIS DOCUMENT WITHOUT WRITTEN PERMISSION IS PROHIBITED.		3000 CAMPUS DRIVE MINNEAPOLIS, MN 55441 1-800-544-7769 (763) 553-7300 (763) 553-0708 fax www.turck.us	
1.		DRFT	RDS	DATE	12/21/06
2.		APVD		SCALE	1=1.0
3.	ALL DIMENSIONS DISPLAYED ON THIS DRAWING ARE FOR REFERENCE ONLY	UNIT OF MEASUREMENT		DESCRIPTION	
4.		MILLIMETER [ INCH ]		PKG 3Z--*--PSW 3M-P7X2	
MATERIAL	CONTACT TURCK FOR MORE INFORMATION	DO NOT SCALE THIS DRAWING		IDENTIFICATION NO.	REV
SEE SPECIFICATIONS				FILE: 777015047	D
FINISH					
SEE SPECIFICATIONS					

D	UPDATED VOLTAGE RATING	TV	07/13/15	50472
REV	DESCRIPTION	BY	DATE	ECO NO.