

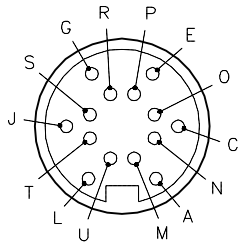

FEMALE PIN-OUT



- A = N/C
- C = ORANGE
- E = BLACK
- G = GREEN
- J = GREY
- L = N/C
- M = BROWN
- N = TAN
- O = VIOLET
- P = RED
- R = WHITE
- S = YELLOW
- T = PINK
- U = BLUE

 M16 connector

SPECIFICATIONS

CONTACT CARRIER MATERIAL	TPU
MOLDED HEAD MATERIAL/COLOR	TPU/YELLOW
CONTACT MATERIAL/PLATING	BRASS/GOLD
COUPLING NUT MATERIAL/PLATING	BRASS/NICKEL
RATED CURRENT [A]	3.0 A
RATED VOLTAGE [V]	30 V
OUTER JACKET MATERIAL/COLOR	PVC/BLACK
CONDUCTOR INSULATION MATERIAL	PVC
NUMBER OF CONDUCTORS [AWG]	12x24 AWG
DRAIN/SHIELD	26 AWG/ALUMINUM-POLYESTER FOIL
TEMPERATURE RANGE	-40°C TO +105°C (-40°F TO +221°F)
PROTECTION CLASS	MEETS IEC IP67

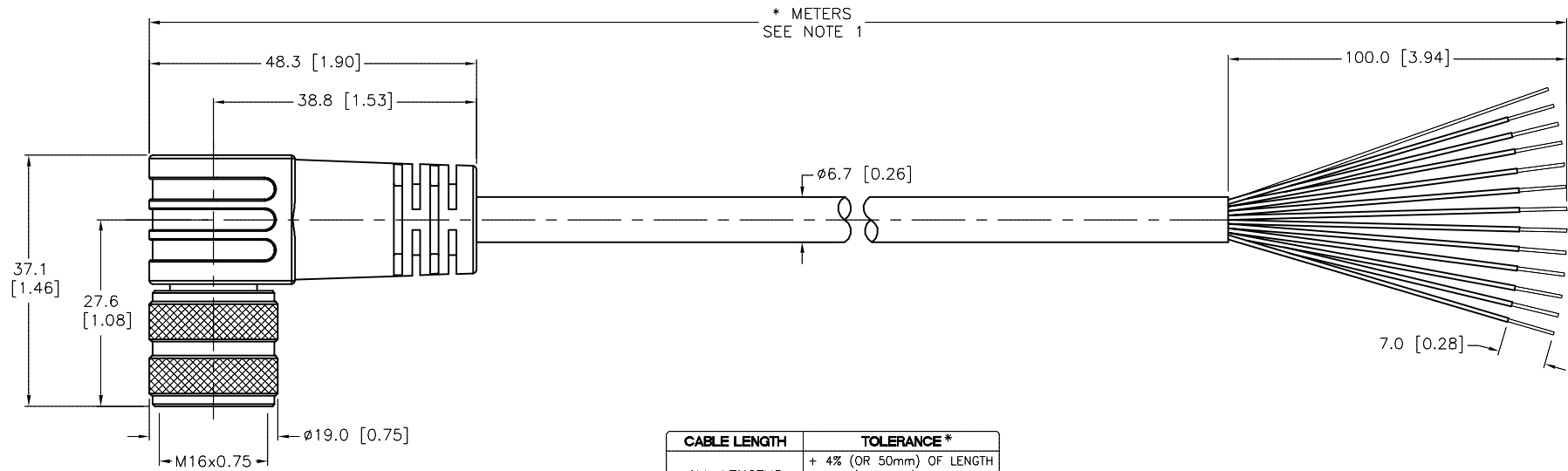



CABLE LENGTH	TOLERANCE *
ALL LENGTHS	+ 4% (OR 50mm) OF LENGTH - 0% (OR 0mm) OF LENGTH WHICHEVER IS GREATER
STRIP LENGTH	TOLERANCE *
0-7mm	±0.5mm
8-29mm	±1.0mm
30-49mm	±2.0mm
50-69mm	±3.0mm
70-100mm	±4.0mm
OVER 100mm	±5.0mm

* UNLESS OTHERWISE SPECIFIED

SOURCE DRAWING - FOR REFERENCE ONLY

NOTES:

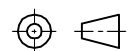
1. "*" INDICATES CABLE LENGTH IN METERS. CONTACT TURCK TO ORDER SPECIFIC LENGTHS.

RELATED DOCUMENTS 1. 2. 3. 4.	3RD ANGLE PROJECTION 	THIS DRAWING IS CONFIDENTIAL AND THE PROPERTY OF TURCK INC. USE OF THIS DOCUMENT WITHOUT WRITTEN PERMISSION IS PROHIBITED.		 <p>3000 CAMPUS DRIVE MINNEAPOLIS, MN 55441 1-800-544-7769 (763) 553-7300 (763) 553-0708 fax www.turck.us</p>	
		DRFT RDS	DATE 04/11/03		
MATERIAL SEE SPECIFICATIONS	ALL DIMENSIONS DISPLAYED ON THIS DRAWING ARE FOR REFERENCE ONLY	APVD SWC	SCALE 1=1.0	IDENTIFICATION NO.	
FINISH SEE SPECIFICATIONS		UNIT OF MEASUREMENT MILLIMETER [INCH]		REV H	
DO NOT SCALE THIS DRAWING		FILE: 777001979		SHEET 1 OF 1	

H	DRAWING PROCESSED AS PART OF ECO 38237	KMY	03/05/12	38237
REV	DESCRIPTION	BY	DATE	ECO NO.