

# BI2-CRS524-ADZ30X2-B1131/S34

## Inductive Sensor – For High Pressures

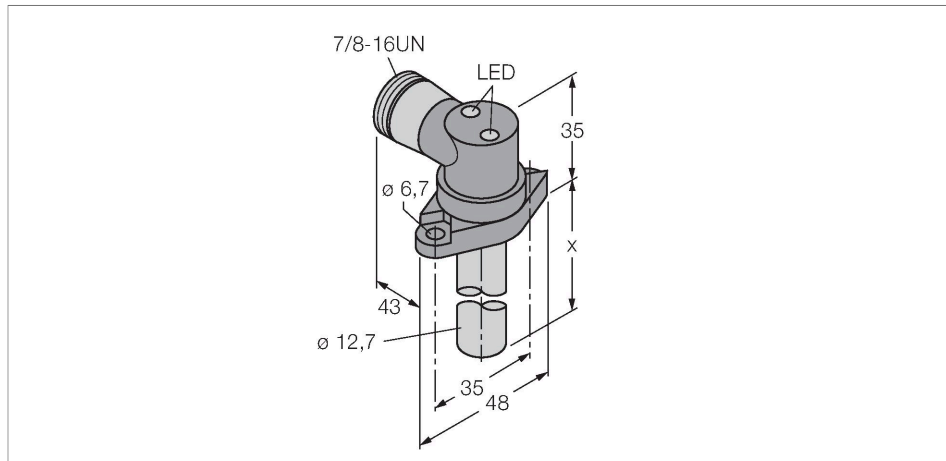

### Features

- Smooth barrel, stainless steel, 1.4305
- Ø 12.7 mm
- Housing, GD-Zn, chromated
- Admissible pressure static/dynamic 200/100 bar
- Magnetic-resistant (insensitive to magnetic DC and AC fields)
- AC 2-wire, 20...250 VAC
- DC 2-wire, 10...300 VDC
- NO contact
- 7/8" male connector

### Wiring diagram

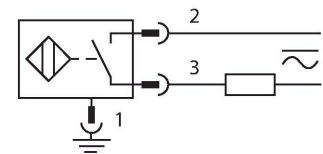

### Technical data

Type	BI2-CRS524-ADZ30X2-B1131/S34
ID	4272093
Special version	S34 corresponds to: Weld-field immune proximity sensors

General data	
Rated switching distance	2 mm
Mounting conditions	Flush
Secured operating distance	$\leq (0.81 \times S_n)$ mm
Correction factors	St37 = 1; Al = 0.3; stainless steel = 0.7; Ms = 0.4
Repeat accuracy	$\leq 2$ % of full scale
Static pressure	$\leq 200$ bar
Dynamic pressure	$\leq 100$ bar
Admissible contact medium	electrically conductive
Temperature drift	$\leq \pm 10$ %
Hysteresis	3...15 %
Electrical data	
Operating voltage	20...250 VAC
Operating voltage	10...300 VDC
AC rated operational current	$\leq 400$ mA
DC rated operational current	$\leq 300$ mA
Frequency	$\geq 50 \dots \leq 60$ Hz
Residual current	$\leq 1.7$ mA
Isolation test voltage	$\leq 1.5$ kV
Surge current	$\leq 3$ A ( $\leq 20$ ms max. 5 Hz)

### Functional principle

Inductive sensors detect metal objects contactless and wear-free. For this purpose they use a high-frequency electromagnetic AC field that interacts with the target. The sensors hosting a ferrite core coil generate the AC field through an LC resonant circuit. Pressure-resistant inductive sensors withstand high pressures which makes them perfectly suited for position control in hydraulic cylinders.

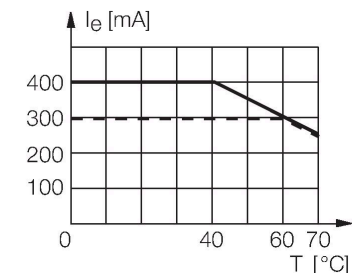

## Technical data

Short-circuit protection	yes / Latching
Voltage drop at I <sub>o</sub>	≤ 6 V
Wire breakage/Reverse polarity protection	yes / Complete
Output function	2-wire, NO contact, 2-wire
Smallest operating current	≥ 3 mA
Switching frequency	0.02 kHz
<b>Mechanical data</b>	
Design	Smooth barrel, 12.7 mm
Probe length	52.4 mm, probe length x
Housing material	Metal, 1.4305 (AISI 303)
Active area material	Plastic, PA12-GF30
Connector housing	metal, GdZn, chromated
Tightening torque fixing screw	7.3 Nm
Electrical connection	Connector, 7/8"
<b>Environmental conditions</b>	
Ambient temperature	-25...+70 °C
Vibration resistance	55 Hz (1 mm)
Shock resistance	30 g (11 ms)
Protection class	IP67
Power-on indication	LED, Green
Switching state	LED, Red
Included in delivery	2 x socket head screw 1/4"-20 NPT, 5/8" long

## Mounting instructions

### Mounting instructions/Description

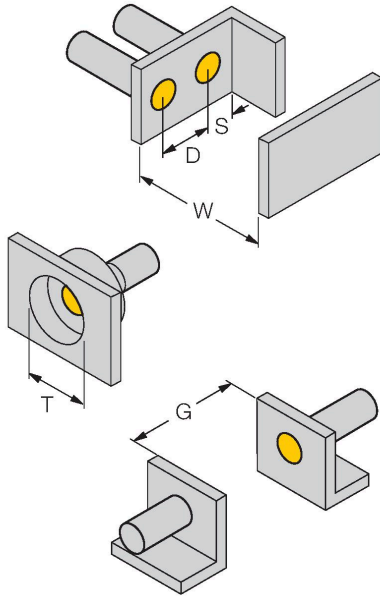

Distance D	2 x B
Distance W	3 x Sn
Distance T	3 x B
Distance S	1.5 x B
Distance G	6 x Sn
Diameter active area B	Ø 12.7 mm

The mounting receptacle and the O-ring supplied with the sensor are approved for high static and dynamic pressure. To ensure that the application is pressure-resistant, the mounting surface must also be designed accordingly. Ensure that the mounting surface is dry and free of dust during installation. Please also consider that oil can be displaced from the hydraulic system when the sensor probe is introduced, in which case the mounting surface will be moistened. Should this occur, a proper seal will not be established.

#### Recommended clearances:

0.64... 1.19 mm to the hydraulic cylinder end position buffers being detected to allow for tolerances and wear.  
 >2.8 mm to the hydraulic cylinder piston rod to ensure that the sensor output switches off.