

BIM-KST-AP6X-V1131

Magnetic Field Sensor – For Pneumatic Cylinders

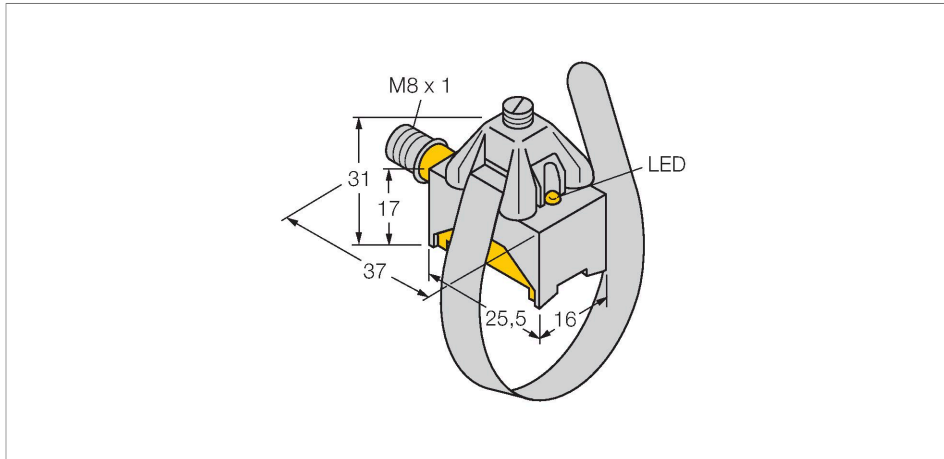

Features

- Rectangular, height 17 mm
- Front active face
- Metal/plastic, GD-Zn/Al/PA12-GF30
- Magnetic-inductive sensor
- DC 3-wire, 10...30 VDC
- NO contact, PNP output
- Male connector, M8 x 1

Wiring diagram

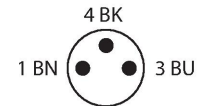
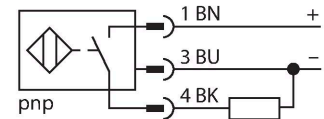

Technical data

Type	BIM-KST-AP6X-V1131
ID	46742
General data	
Pass speed	≤ 10 m/s
Repeatability	≤ ± 0.1 mm
Temperature drift	≤ 0.1 mm
Hysteresis	≤ 1 mm
Electrical data	
Operating voltage	10...30 VDC
Residual ripple	≤ 10 % U _{ss}
DC rated operational current	≤ 200 mA
No-load current	15 mA
Residual current	≤ 0.1 mA
Isolation test voltage	≤ 0.5 kV
Short-circuit protection	yes / Cyclic
Voltage drop at I _o	≤ 1.8 V
Wire breakage/Reverse polarity protection	yes / Complete
Output function	3-wire, NO contact, PNP
Switching frequency	1 kHz
Mechanical data	
Design	Rectangular, KST
Dimensions	37 x 16 x 17 mm
Housing material	Metal/plastic, GD-ZN/Al/PA12-GF30
Active area material	Plastic, PA12-GF30

Functional principle

Magnetic field sensors are activated by magnetic fields and are especially suited for piston position detection in pneumatic cylinders. Based on the fact that magnetic fields can permeate non-magnetizable metals, it is possible to detect a permanent magnet attached to the piston through the aluminium wall of the cylinder.

Technical data

Electrical connection	Connector, M8 × 1
Environmental conditions	
Ambient temperature	-25...+70 °C
Vibration resistance	55 Hz (1 mm)
Shock resistance	30 g (11 ms)
Protection class	IP67
MTTF	2283 years acc. to SN 29500 (Ed. 99) 40 °C
Mounting on the following profiles	
Cylindrical design	○
Switching state	LED, Yellow
Included in delivery	KST-SE, KST-MG, KST-SB170, KST-SB335

Accessories

KST-SB170

46737

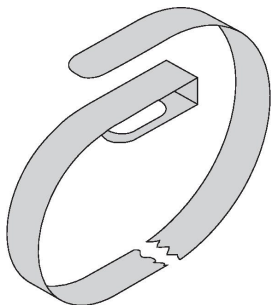

Clip collar for mounting magnetic field sensors on round cylinders; cylinder diameter 8...25 mm, material: Metal A2 1.4301 (AISI 304)

KST-SB335

46738

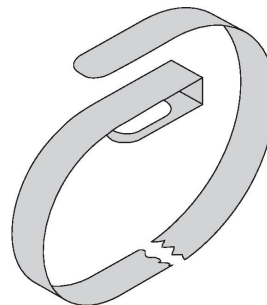

Clip collar for mounting magnetic field sensors on round cylinders; cylinder diameter 8...80 mm, material: Metal A2 1.4301 (AISI 304)