

Gateway for BL67 I/O system
Interface for EtherNet/IP™ (slave) with DeviceNet™ scanner
BL67-GW-EN-IP-DN

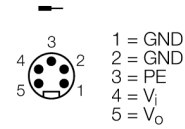
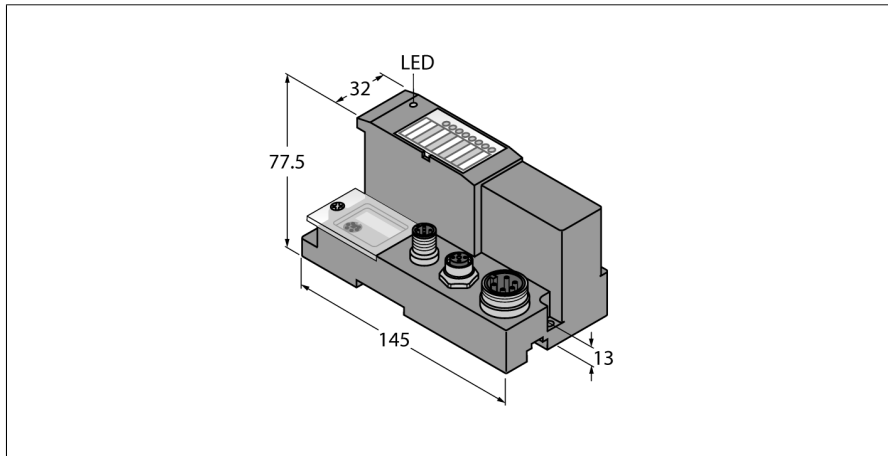

Functional principle

BL67 gateways are the head component of a BL67 station. They are designed to connect the modular fieldbus nodes to the higher level fieldbus (PROFIBUS-DP, DeviceNet™, CANopen, Ethernet Modbus TCP, PROFINET IO or EtherNet/IP™).

All BL67 electronic modules communicate over the internal module bus, the data of which is transferred to the fieldbus via the gateway. As a result, all I/O modules can be configured independently of the bus system.

DeviceNet™ subnet

This gateway features a fieldbus-slave interface and a DeviceNet™ scanner (master). The DeviceNet™ scanner enables the connection of DeviceNet™ slaves. The process data of the slaves are mapped to the process image of the BL67 system.

Type designation	BL67-GW-EN-IP-DN
Ident-No.	6827299
Supply voltage	24 VDC
Admissible range	18...30 VDC
Nominal current from module bus	≤ 600 mA
max. system supply current I _{mb (SV)}	1.3 A
Max. sensor supply I _{sens}	4 A electronically limited current supply
max. load current I _L	10 A
Voltage supply connection	5-pin male 7/8" connector
Fieldbus transmission rate	10/100 Mbps
Fieldbus addressing	rotary switch, BOOTP, DHCP, IO-ASSISTANT
Fieldbus connection technology	Female connector, M12 x 1, 4-pin, D-coded
Input process image	128 words
Output process image	128 words
Service interface	RS232 interface (PS/2 socket)
Dimensions (W x L x H)	74 x 145 x 77.5mm
Approvals	CE
Operating temperature	-40...+70 °C
Temperature derating	
> 55 °C Circulating air (Ventilation)	no limitation
> 55 °C Steady ambient air	I _{sens} < 3A, I _{mb} < 1A
Storage temperature	-40...+85 °C
Relative humidity	5 to 95 % (internal), Level RH-2, no condensation (at 45 °C storage)
Vibration test	acc. to EN 61131
Extended vibration resistance	VN 02-00 and higher
- up to 5 g (at 10 to 150 Hz)	for mounting on DIN rail no drilling according to EN 60715, with end bracket
- up to 20 g (at 10 up to 150 Hz)	for mounting on base plate or machinery Therefore every second module has to be mounted with two screws each.
Shock test	acc. to IEC 68-2-27
Drop and topple	acc. to IEC 68-2-31 and free fall to IEC 68-2-32
Electromagnetic compatibility	acc. to EN 61131-2
Protection class	IP67
DIN rail mounting	yes, Attention: Offset
Direct mounting	Two mounting holes, 6 mm Ø
Included in delivery	1 x end plate BL67

Gateway for BL67 I/O system
Interface for EtherNet/IP™ (slave) with DeviceNet™ scanner
BL67-GW-EN-IP-DN

Pin configuration and supply concept

	<p>DeviceNet™ Scanner (Master)</p> <p>The DeviceNet™ scanner enables the configuration of a DeviceNet™ subnet. DeviceNet™ slaves of any manufacturer can be connected.</p> <p>The DeviceNet™ slaves are not supplied by the BL67 system. External power supply required.</p>	<p>Pin Assignment</p> <ul style="list-style-type: none"> 1 = Shield 2 = RD (n.c.) 3 = BK (V₋) 4 = WH (CAN H) 5 = BU (CAN L)
	<p>EtherNet/IP™ Slave</p> <p>The M12-D coded Ethernet port is used as interface for configuration and fieldbus communication. The gateway can be operated as a slave at PLCs or PC based systems with EtherNet/IP™ scanner (master).</p>	<p>Pin Assignment</p> <ul style="list-style-type: none"> 1 = YE (TX +) 2 = WH (RX +) 3 = OG (TX -) 4 = BU (RX -)
	<p>Power Supply</p> <p>Double-tuned power supply of the BL67 system.</p> <p>System power supply V_i</p> <p>V_i is for the internal system supply at the backplane bus ($V_{MB(SV)}$) and for the 4A short-circuit limited sensor supply (V_{sens}).</p> <p>Load voltage V_o</p> <p>V_o for output supply, limited to max. 10A.</p>	<p>Pin Assignment</p> <ul style="list-style-type: none"> 1 = GND 2 = GND 3 = PE 4 = V_i 5 = V_o <p>Power supply</p> <p>The diagram shows a dashed line separating the 'System supply' (top) and 'Field supply' (bottom). In the system supply, VMB (5 V) and IMB (5 V) are connected to the backplane bus. In the field supply, VMB (24 V) and IMB (24 V) are connected to the backplane bus. A 4 A current limit is shown between the field supply and the sensor supply (I_{sens}). The output supply (I_o) is also shown.</p>

Gateway for BL67 I/O system

Interface for EtherNet/IP™ (slave) with DeviceNet™ scanner

BL67-GW-EN-IP-DN

LED functions

LED	Color	Status	Description
IO		OFF	No power supply
	GREEN	ON	Station OK
	GREEN	FLASHING (1Hz)	Station in force mode of the I/O-ASSISTANT
	GREEN	FLASHING (4 Hz)	The max. admissible number of modules connected to the gateway is exceeded.
	RED	ON	Insufficient power supply
	RED	FLASHING (1Hz)	The current station configuration does not comply with the configured module list.
	RED	FLASHING (4 Hz)	No module bus communication.
	RED/GREEN	FLASHING (1Hz)	The current and configured module list do not match but the data exchange proceeds as normal.
GW		OFF	No power supply of the CPU.
	GREEN	ON	Firmware active, gateway ready
	GREEN	FLASHING (1Hz)	Firmware inactive.
	GREEN	FLASHING (4 Hz)	Firmware active, gateway hardware error.
	RED	ON	CPU not ready, Vcc too low. Causes of failure: - Too many modules at the gateway - Short circuit in one of the modules - Defective gateway
Vcc	GREEN	ON	CPU and module bus OK
		OFF	No supply of CPU or short-circuit of the module bus supply.
Vo	GREEN	ON	Supply of outputs OK
	GREEN	FLASHING (1Hz)	Undervoltage Vo; system running.
	GREEN	FLASHING (4 Hz)	Undervoltage Vo; system running.
		OFF	No power supply.
Vi	GREEN	ON	Sensor and system supply OK.
	GREEN	FLASHING (1Hz)	Undervoltage Vi; system running.
	GREEN	FLASHING (4 Hz)	Undervoltage Vi; system running.
	RED	ON	Short-circuit or overload at the sensor supply Vsens.
		OFF	No power supply.
DN		OFF	CAN error and/or sub-bus is offline.
	GREEN	ON	TheDeviceNet™ subnet is active, communication OK.
	GREEN	FLASHING	TheDeviceNet™ subnet is ready but not active.
	RED	ON	One DeviceNet™ MAC ID (station address) is assigned twice.
	RED	FLASHING	Empty DeviceNet™ slave station list or excess of admissible data volume. 512 byte I/O data for the slaves and 500 byte for the whole station.
	RED/GREEN	FLASHING	One or more of the configured slaves is/are not online.
LNK/ACT	GREEN	ON	Link established, 100 Mbps
	GREEN	FLASHING	Ethernet traffic with 100 Mbps
	YELLOW	ON	Link established, 10 Mbps
	YELLOW	FLASHING	Ethernet traffic with 10 Mbps
		OFF	no Ethernet link.
MS	GREEN	ON	An EtherNet/IP™ scanner (master) has established an Ethernet connection to the gateway.
	GREEN	FLASHING	Gateway ready, EtherNet/IP™ connection inactive.
	RED	ON	Gateway error.
	RED	FLASHING	DHCP/BootP search for settings.